

FRANK'S BOOK OF THE TELESCOPE

Frank's Book of the
TELESCOPE

A guide to instruments
FOR
the Amateur Astronomer

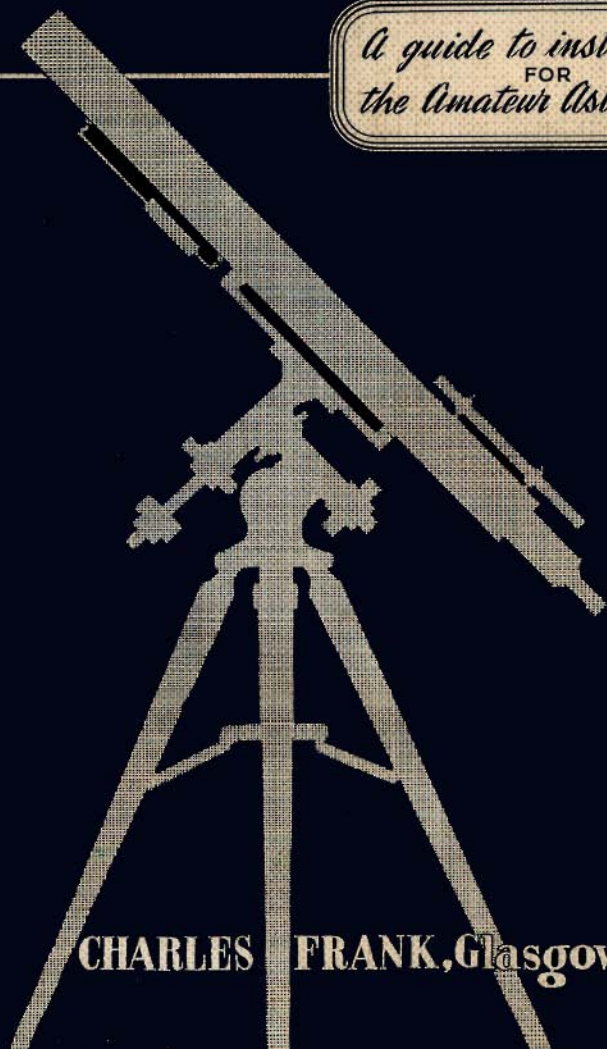

CHARLES FRANK, Glasgow



A simply constructed 6 inch Newtonian telescope details of which are given in Chapter XV. The telescope can be mounted on an ex-Government tripod like this one or for greater stability, a four-legged stand can be easily made.

FRANK'S BOOK OF THE TELESCOPE



Published by
CHARLES FRANK of the SALTMARKET, GLASGOW

MCMLIX

FIRST EDITION, October 1958
SECOND EDITION (Revised), March, 1959

Copyright 1959 by CHARLES FRANK
Reproduction in whole or in part prohibited

Printed in Great Britain by
POLLOCK BROS. & CO., GLASGOW, C.5

FOREWORD

by Arthur Frank, F.B.O.A.

THE PURPOSE of this small book is twofold. I have felt for some time that there is a real need for a brief and practical introduction to the various types of telescope available as a result of sales of Government equipment, and, the greatly increased interest in astronomy seemed to make it desirable that the potentialities of such instruments should be examined with a view to their use on astronomical subjects.

Many of the telescopes which come from Government sources are of extremely fine quality and well-suited to certain types of astronomical work, particularly in those fields of study not calling for high magnifying powers. In some cases it is possible to obtain very considerable magnification when the user is able to undertake certain modifications; haphazard alterations, however, are more than likely to impair the qualities of these instruments.

Many users of these low-power telescopes have come eventually to feel the need for telescopes of a more highly specialised form. There are also many people, especially among the very young, for whom the cost of low-priced ex-Government instruments is greater than they can afford. In this book will be found guidance for those who wish to make for themselves the most simple of all astronomical telescopes—one

FOREWORD

which need cost no more than a few shillings to make. Such a telescope, used properly, is an educational instrument, not a toy. In fact there is much to be said for urging even those possessing large and powerful telescopes to construct for themselves one of the very minor instruments—so similar to those with which the first great strides of astronomical progress were made—by Galileo, Huyghens, Kepler and others. The “first telescope” of many observers who are today widely known and respected for their astronomical work, was of this type.

Those determined on more ambitious telescopes will find much to interest and encourage them in this work; the six-inch reflecting telescope described in these pages is one that can be made with the absolute minimum of equipment, calling for nothing more than the intelligent use of ordinary hand tools.

We should like to take this opportunity of thanking Terence Maloney, F.R.A.S., for his share in the preparation of the original manuscript. We are also indebted to Lionel Levy, M.A., and Dr. E. Golombok for their help with this edition.

CONTENTS

	Page
FOREWORD by Arthur Frank, F.B.O.A.	
CHAPTER I Light and the Function of the Lens	1
CHAPTER II The Simplest Astronomical Telescope	6
CHAPTER III What to Expect from the Telescope	11
CHAPTER IV What Size of Telescope?	18
CHAPTER V War-Surplus Telescopes	25
CHAPTER VI What Type of Astronomical Observation?	32
CHAPTER VII Mounting Problems; Astronomical “Seeing”	36
CHAPTER VIII The Amateur’s Newtonian Reflector	41
CHAPTER IX Astronomical Photography for the Amateur	53
CHAPTER X Using the Telescope; General Principles	62
CHAPTER XI Telescopic Eyepieces	68
CHAPTER XII Attachments and Auxiliaries	79
CHAPTER XIII Specialised Instruments	82
CHAPTER XIV Catadioptric Systems	99
CHAPTER XV Making a Reflecting Telescope—and Mounting It	109
APPENDIX—Books Worth Reading	124
INDEX	131

CHAPTER I

Light and the Function of the Lens

IT IS remarkable that so much of man's knowledge concerning the universe has resulted from the use of such a simple instrument as the telescope. For the telescope is, in its essentials, one of the simplest and most straightforward of devices.

While many instruments of modern research are apt to bewilder by their complexity, the real wonder of the telescope is the utter simplicity of the means by which it makes use of the nature of light and of the materials from which its most important parts are made; from a few ounces of silica, lead, soda and alumina is it possible to create the optical elements of an instrument which will probe into space across distances that cannot be measured in everyday terms of miles or kilometres, but which can only be conveniently expressed with reference to the number of years it would take light, travelling at 186,000 miles per second, to cover the same distance.

Of all the forms that the telescope can be given, that of the specialised astronomical instrument is the most simple of all, and is, as it were, the *basic instrument* from which the other types are derived.

In this discussion of the merits of the various types of telescope suitable for the amateur astronomer and the teacher of astronomy, it will be necessary to use certain simple standard terms with which many people—interested in practical optics but ignor-

ant of its principles—will be unfamiliar. It is hoped in this small work to explain these terms.

Long before the telescope was discovered the means of creating it had existed; the ability of glass to refract or bend rays of light passing through it must have been an item of knowledge gained almost as soon as it became possible to make glass. Experiment has shown that the extent to which a ray of light was bent, or its direction altered, on passing through glass, depended upon the angle at which it met the surface of the glass. The lens, whatever form it takes, is simply a means by which this principle is applied to ensure that the individual rays striking it and passing through it, are so diverted that they are given a new, and calculated direction. Since the telescope utilises rays which can for all practical purposes be regarded as parallel to each other it is immediately clear that a curved, spherical, surface will intercept such a bundle of rays so that the angle at which each individual ray strikes, depends upon how far from the central, or axial ray, it happens to lie. The diagram will make this clear.

It will be noticed that, in the lens form shown, the central, or axial ray passes through the lens

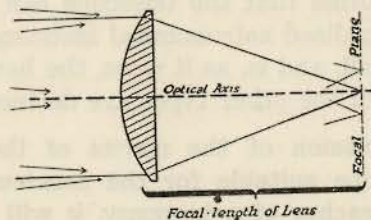

without deviation while those rays nearest the edge of the lens are "bent" the most; it will also be seen

that there is a second deviation of all the non-axial rays, on emerging from the glass. This second deviation can readily be seen to depend on the angle at which the individual rays meet the air-surface at the back of the lens. No harm will result if, at this point, we consider what happens if such a lens as this, a plano-convex lens, is reversed, so that the flat side is presented to the source of light.

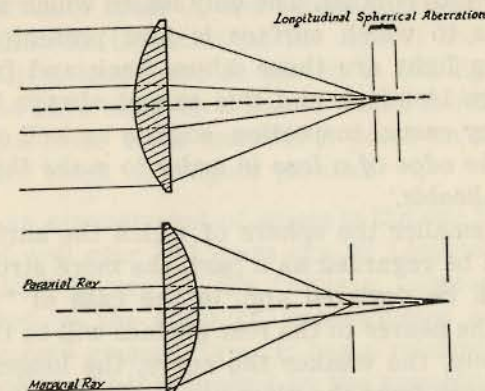

When the lens is reversed in this fashion, *all* the rays meet the first surface of the glass at the *same* angle, and, as a consequence, suffer no deviation, until reaching the point at the back of the lens, where each passes once more into the air. Naturally, such a reversal results in a decided alteration in the action of the lens; not only is the point at which the individual rays meet (the focus) shifted to a new position along the axis, but a number of other characteristics, which need not concern us at the moment, are altered. The importance of ensuring that the elements of any optical instrument that has been dismantled are *re-assembled the right way round* cannot be over-emphasised.

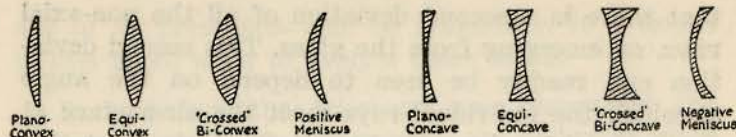

Lens-Forms

The diagram above shows the basic forms of the lenses with which the amateur astronomer is likely to come into contact. The only lenses which are indifferent as to which surface is first presented to the incoming light are those whose back and front surfaces are identical, and this cannot always be determined by casual inspection, so it is as well *always* to mark the edge of a lens in order to make the "front" unmistakable.

The smaller the sphere of which the surface of a lens can be regarded as a part, the more strongly the rays will be deviated and, in the case of "positive" lenses, the nearer to the rear surface will be the focus. Conversely, the weaker the curve, the longer will be the distance from the glass at which the rays come to a focus. The longer the focus, the greater the scale of the image. This image that the object glass forms of a distant object, can be viewed as though it were itself an object by looking through a suitable lens. The more "powerful" this lens happens to be, the closer can the eye be placed to the image, and the larger it will appear to the observer. Such an arrangement of lenses is, in essence, an astronomical telescope. Reference to the diagrams will make it clear that groups or bundles of rays coming from parts of the object which lie *below* the optical axis are brought to a focus in the image-plane *above* the axis; in other words, the image is inverted and is thus seen by the observer. This is no disadvantage in

astronomy. There are various ways in which this inversion of the image can be cured or circumvented. One is by inserting an inverting prism, or prism-train, in the light path; another is by using a lens system in front of the eyepiece proper to bring about a second inversion and produce a new, and erect, image to be viewed through an eyepiece. The inversion of the image can be circumvented altogether by using a "negative" lens (that is, one whose edge-thickness is greater than its thickness at the centre) for an eyepiece; such a lens must be placed in the light path *before* the rays come to a focus, where it will divert them from their track towards a point on the axis, and render them once again parallel.

Such an arrangement of lenses is the one that was first used well over 300 years ago by Lippershey and Galileo. Still known as the Galilean telescope, it is today used in the form of opera-glasses and non-prismatic field glasses. True, it has a relatively small field of view, which is limited by the apparent size of the object glass as viewed through what is virtually a "diminishing glass"; but it has the advantages of excellent definition (when the instrument is a good one) and high light-transmission without internal reflections. For these reasons it has long been in favour as a "night field-glass," especially at sea, where the avoidance of internal reflections is important.

Owing to the small number of optical surfaces contained in this instrument, it is relatively easy and cheap to produce.

CHAPTER II

The Simplest Astronomical Telescope

SO FAR the action of various types of lens on the light which passes through them has been considered as though all the rays were treated similarly by the glass. We have to modify this when we come to consider *colour* as a property of light. Although for many aspects of instrument design, light can be regarded as travelling in straight lines it is in fact a form of energy propagated in much the same fashion as other forms of electro-magnetic disturbance, such as X-rays and radio-waves. The eye is far less sensitive to colour than might be supposed, and is generally unable to distinguish whether coloured light is "pure" or whether its apparent colour is really a *compound* of quite separate colours. Glass, on the other hand, *can* distinguish; and one of the problems of the practical optical worker is so to make his instruments (when they are intended to create a realistic image of an object) that this distinction, which glass makes, and the different manner in which it behaves towards light of different colours, does not interfere to a damaging extent with the intended function of the instrument. Light of different colours (and "white" light invariably is a compound of "coloured light") is selectively treated by a glass lens so that some colours are more sharply bent than others both on entering and leaving the lens; this is precisely the same sort of thing which enables light to be broken up into its constituent parts by a prism, and, for many purposes,

THE SIMPLEST ASTRONOMICAL TELESCOPE

it is possible to regard a lens as a specialised form of prism.

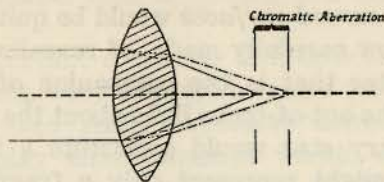

This separation of the rays of light according to colour, results in their intersecting at different points on the optical axis. If the light reaching the lens were composed of blue and orange light, two quite distinct images would be formed at different points on the axis. In other words the lens would have a different focal length in blue light from that which it had in orange. Observation of the blue image would show it to be surrounded by an orange haze resulting from the "out-of-focus" orange image, and vice-versa. This is exactly what happens when a simple lens made entirely from one type of glass is used to focus an image, except that there are usually not two but hundreds of images, in different (even if only very slightly different) colours, and that these multiple images overlap to an almost unlimited degree. The fact that such an effect does not result in the total destruction of the observed image is an indication of the relative insensitivity of the eye to the more extreme parts of the visible spectrum.

With any single glass, the degree of colour dispersion bears a relationship to the amount of bending of the individual rays which takes place as the light passes through it, and for this reason, when even observatory instruments had to rely on such simple types of object glass as could be made from a single

lens, the focal length of telescopes was very great in proportion to their diameter. A simple object glass *with steeply curved surfaces* would be quite incapable, no matter how carefully made, of revealing the tenth magnitude star that is the companion of the bright star Vega. The out-of-focus light about the main image of the primary star would constitute a haze which, although it might represent only a fragment of the total light passing through the telescope, would be more than enough to swamp completely the image of the bright star's faint companion. Application of a higher-power eyepiece to magnify the distance between the two would magnify the extent of the out-of-focus image also; the moral is, of course: *what a telescope won't reveal with moderate power it will not reveal with an immoderately high power.*

Today, the experimenter—and the schoolboy who wishes to make a telescope for an absolute minimum of expense and can afford to pay only for an object glass of a “non-achromatic” variety—is following in the footsteps of the early astronomers. Good luck to him. He will learn a good deal, not only concerning practical optics, but about astronomy, too, if he takes advantage of the lessons learned by those who have travelled the road before; and among them are a number of illustrious predecessors.

These lessons indicate that he should choose for his object-glass a lens of long focus relative to its diameter; a useful choice would be a glass of $1\frac{1}{2}$ to 2 inches in diameter and something like 40 inches in focal length. The lens should be possessed of a proper optical polish, well figured, and not smothered with scratches. Scratches scatter light, and a single deep

gash is infinitely less damaging than a haze of minute ones. A *moulded* lens is useless and best forgotten.

It is important to realise that optical instruments are the result, very largely, of some sort of compromise, and even really expensive astronomical telescopes display characteristics which would render them quite unsuitable for work requiring a large field of view, even though such work might be of a far less critical type than that for which the telescope is *designed*. To make our very simple non-achromatic instrument perform as well as possible in its allotted task it may be that a further compromise in the direction of reduction of aperture and, therefore, light-grasp will have to be made. There is no need to be afraid of “stopping down” the lens in this way; unless the focal length of the glass is already quite exceptional it is likely that the improved achromatism of the telescope (and, consequently, its defining power) will far outweigh the loss of light from the outer parts of the lens. Experiment will quickly show just what is the most effective aperture for any given glass, just as it will reveal that a very real improvement can result from a very small reduction in diameter. Not only will the chromatic effects become less obtrusive but there will be a more perfect focussing of the light of any single colour. Any lens made of a single glass, having surfaces which are spherical in form, must introduce *spherical aberration*: the light passing through different zones of such a lens will intersect the optical axis at different distances along it, in such a way that the light refracted by the outer zones is focussed nearer to the glass than that which passes through the central zones. If this condition is severe, no considerable magnification of

the image is likely to be effective, although with a very low-power eyepiece the view presented by such an object glass might seem very pleasing. Reduction of the size of the lens by means of a "stop" will ensure that the light refracted by the object glass is brought to a more perfect focus, with the intersection of the various rays with the axis forming much more nearly an ideal "point," instead of a line along part of its length. These matters are emphasised since some disquiet may be felt concerning the possible effectiveness of a telescope object glass, already small, being made yet smaller. In any case, if it should prove essential to reduce aperture, it may be a consolation to reflect a little upon the resolving power of even a small lens.

CHAPTER III

What to Expect from the Telescope

THE ABILITY of a small instrument to reveal distant detail is a good deal greater than most people are apt to suppose.

A "perfect" telescope of one inch aperture is able to show the separate components of a double-star even if the distance between them is as little as 4.5 seconds of arc. In terms of ordinary terrestrial measurement this is like saying that two separate lamps could be seen as two separate light sources from a distance of 250 miles *providing the actual distance between them were not less than about ten yards.*

Such a telescope is itself far from being a toy in the hands of a person knowing how to get the best from it. With a low power eyepiece, used at night in a clear sky, it will reveal the Milky Way as a glorious sight that will not easily be forgotten. Stars down to the ninth magnitude will be seen, and close examination of many of those which appear solitary to the unaided eye, will show them to be double or triple systems.

Appearance of the Moon in a One-Inch Telescope

A really good one-inch telescope, which need not be expensive, will bear very considerable magnification by high-power eyepieces. This is encouraging for those who wish to explore the sky in some detail, since, for

objects that are very close together, a reasonable amount of magnification is required for an average eye to distinguish them. The same applies to planetary and lunar detail as to stars, although the virtues of extreme magnification are likely to be overrated by the inexperienced. With a power of 40x, our theoretically perfect one-inch telescope will show the planet Jupiter as a disc of approximately the same size as the full moon appears to be to the naked eye, and reveals the fact that its equatorial diameter is considerably greater than the distance that separates its N. and S. Poles. The Moon itself, seen through such a telescope and under the same conditions of magnification, would not simply fill a great proportion of the entire field of view, but it would under the right conditions of illumination, be clearly seen as a very solid real world, with enough of the details of its landscape discernible and thrown into sharp relief, to leave no doubt in the beholder's mind that our satellite is a very different world from that which is our home. Not only the "seas" and great ringplains would be seen; craters on the surface of this world, a quarter of a million miles distant from us, would be clearly visible even if they were only five miles or less in diameter. Craters of this order of size are to be numbered by the hundreds on the lunar surface, and, especially when they lie near the terminator (the region where the sun happens to be rising or setting on the moon) their form and variety can well be appreciated with the aid of a small telescope.

Before first-quarter and after third-quarter phases of the Moon, the small one-inch telescope will show us something very fascinating if turned towards the Moon with a low-power eyepiece, especially at third-

quarter and afterwards, particularly around six o'clock in the morning in October, when the third-quarter Moon rides high in our British skies. The "dark" portion of its surface can be seen very clearly—illuminated not by light that it is receiving directly from the sun, but by that which is reflected to it from the surface of our own planet. This gives us a very good idea of just how brilliant the Earth would appear in the sky if seen from the Moon. Remember, the surface of our satellite is intrinsically dark and dull; yet the sunlight, after two reflections from such indifferent reflectors as, first, the Earth, and then the Moon, is still bright enough to be seen across a quarter of a million miles of space, and through the very effective light-filter that our atmosphere is known to be. Such small experiments as this will do much to bring home to the young, and to the not-so-young enthusiast, facts which no book of instruction can bring to life in quite the same way. This type of personal verification is one of the minor pleasures of the telescope, and one that can be repeated in endless variety, at leisure, with limitations imposed more by the amount of time available for such study, than by any other factor.

The Sun—A Warning

Before passing from consideration of the one-inch telescope, just a word or two about the Sun. A telescope even as small as this is a good instrument for studying the Sun under the right conditions. *Used wrongly, even the smallest telescope can result in the Sun doing incurable damage to the eye of the user; yet the precautions that need to be taken to ensure that such damage is impossible are simple and need cost*

so little that there is no excuse for taking the slightest risk.

No recommendations will be made here concerning the various "sun-caps" and filters that are intended to permit direct observation of the Sun through the telescope. Even when such appliances reduce the glare so that the eye is able to look at the Sun directly, only by testing the device can one know how effective it might be in filtering out the intense infra-red, invisible, radiation that is being concentrated upon it by the object glass of the telescope. Even should the sun-cap be an effective filter of infra-red, as well as of visible light, such glasses have frequently been known to fracture through expansion in their brass mounts under the application of the heat that is focussed upon them; complete and sudden shattering of such a dark-glass is by no means unknown, and should this happen there is little time to withdraw the eye before a highly concentrated beam of heat rays penetrates to the retina causing almost certainly a permanent "blind spot."

Observation of the Sun and of sunspots is the easiest thing in the world to undertake safely if one has the right sort of equipment. Failing the possession of a special sun-diagonal, by far the best method is to use the telescope as a projector, and focus the Sun's image upon a suitable screen. A very simple and extremely inexpensive arrangement of this kind is shown diagrammatically on this page. Such an arrangement can readily be made by anyone able to bend stiff wire and use a pair of tinsnips. One advantage of this "camera-obscura" method of observing the Sun is that it is simplicity itself to arrange the

apparatus so that more than one person can observe at the same time.

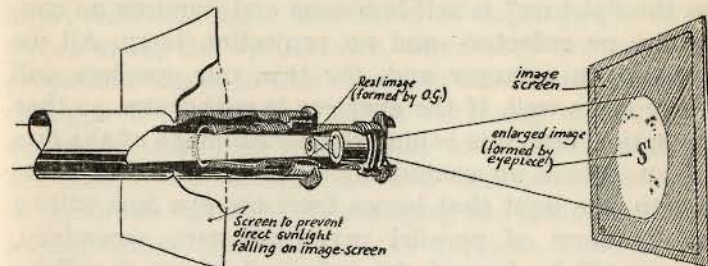

THE EYEPIECE AS AN ENLARGING LENS—Observing the Sun by projection

How to Observe the Sun

When used for projection instead of for observation, the telescope requires to be focussed in a special manner. In the first place, the eye itself is no longer in its customary position to act as a "supplementary lens" for the purpose of forming a secondary image on the retina; a secondary image still has to be formed—on the white screen, without any further attachment to the object-glass and eyepiece combination.

What happens is that the object glass forms an image of the Sun in the telescope tube in the usual way. Such an image is called, in the language of optics, a "real" image, one that would result in a permanent record if a photographic plate were put in the position where it is formed. This photograph, however, taken with the aid of a one-inch telescope of anything like normal focal length, would be of exceedingly small scale, so we now enlarge this real image and project it on to the screen by means of the eyepiece as described below.

For our purpose, the aerial image of the Sun is just as real a picture as if it were already on a photo-

graphic plate; better than that, it is a re-creation of the Sun itself on a minute scale in our telescope tube, so the "picture" is self-luminous and requires no condenser or reflector—and no projection lamp. All we need is an enlarger and, for this, our eyepiece will serve quite well. If the eyepiece is withdrawn so that its optical centre is behind the aerial image of the Sun to an extent approximately equal to its own focal length, the light that issues from the eye lens will be in the form of parallel rays; the new, secondary, image will be formed "at infinity," where it will be quite useless for our purpose. Interception of the beam by the focussing screen will show little beyond vague shadows, and perhaps sharp dark spots which are likely to be shadows thrown by specks of dust and dirt on the eyepiece itself.

Immediately we draw the eyepiece further from the telescope tube the secondary image will leave its position at an infinite distance and begin to approach the telescope. A position in which the eyepiece will form an enlarged image of the Sun at a convenient distance from the end of the telescope tube will quickly and easily be found. No hard and fast rule can be given; the requirements are that the image should be large enough to make it possible to see the smaller details, and bright enough to make the dark parts of the sunspots appear reasonably black despite their being simply shadows cast on white paper. The size of the telescope and the transparency of the sky will largely determine just how large an image of the sun will prove best. The focal length and field of view of the eyepiece used will decide whether the whole, or only part, of the Sun's disc is pictured on the screen. When the eyepiece seems to have been adjusted to produce the sharpest possible picture a further slight

adjustment of the screen itself, nearer to, or further from the eyepiece will probably effect yet further improvement. Slight movement of high power eyepieces along the optical axis, when they are used as projection lenses in this way, can result in enormous changes in the distance of the focussing screen, and are consequently far more tricky to focus; when they are used, it will usually be found far more convenient to focus the "picture" by changing the position of the screen rather than that of the eyepiece. More satisfactory in every way as a rule are low- or moderate-power eyepieces.

CHAPTER IV

What Size of Telescope?

ALL the remarks made on the operation of a small and, so far, hypothetical one-inch astronomical telescope may seem of little interest to those who have set their hearts on an instrument of a size sufficient to astonish their friends by the sheer magnificence of its presence. These remarks may seem surprising to those who have for some reason felt that only telescopes of overpowering size can be of any real use in astronomy.

Quality being similar, a large telescope will quite naturally show more than a small one under good conditions. It will show finer planetary detail and it will separate closer double stars (and closer-spaced terrestrial lamps). It will also enable fainter stars to be seen than can be captured by the small telescope just as the small one shows an advantage over the naked eye. To take the last point first; the reason for its showing fainter stars is fairly obvious. Every star, whether we can see it or not, is emitting light in all directions, so that we can regard the light from it as a completely spherical shell at the surface of which the observer is always placed. This "shell" is, of course, the expanding wave-front of which a small portion, too small for us to notice, enters our eye when we look in the direction of a star that is "too faint to be seen." The greater the size of the object-glass the greater will be the proportion of this wave-front that is intercepted and brought to a focus;

hence we speak of a large telescope having "large light-grasp." A telescope with a large light-grasp and made of materials of high light transmission will therefore produce a brighter image of a star than one without such qualities. But this tells us nothing of the reasons for the larger telescope being able to render finer detail and separate objects lying close together, and at vast distances from the observer. While we frequently talk of a point source of light there is no such thing as a *point image* of a light source except as a desirable, but quite unobtainable, virtue of the "ideal" instrument. The image of a star, or any other point source, in even the finest telescope has a very decided size, and if sufficient magnifying power is applied at the eyepiece end of the instrument this is very quickly made apparent. Such an image is not even a simple spot of light, but, in the best instruments, a spot surrounded by a series of rings. These rings of light rapidly diminish in brightness as they are progressively more distant from the central spot of light. The larger and more perfect the telescope the smaller will be the central spot and the brighter it will be. While in a small telescope a star might appear as a single bright spot, a large telescope, if conditions are right, will often reveal two smaller spots almost touching one another; a yet larger telescope, since it permits an even greater concentration of light, will permit also a far higher degree of magnification before the apparent points of light appear as unmistakably spots of appreciable size, and by then they can be easily observed by the astronomer to be separate.

Resolution and Magnification

When a continuous surface, such as that of a planet, is viewed through a telescope, each point of the

surface produces its own diffraction pattern as an "image." The total surface, therefore, produces an infinite series of such "images." If each of these is of any appreciable size, it is quite plain that fine dark detail such as Martian "canals" must be expected to be invisible. When this is so no amount of eyepiece power will make them visible. *The material is simply not there for the eyepiece to magnify.* The situation can be compared to putting one's eye close up to a television screen in order to examine some minute feature in the remote background of one picture.

Choosing a Telescope

Telescopes of good quality can never be made as cheaply as articles that are mass-produced, and the larger they are, in general, the more expensive they are likely to be. It becomes important at this point in our discussion to consider some of the facts which should be taken into account when coming to choose a telescope. We have already seen that it is possible to make a very simple telescope from an object glass comprising a single long-focus lens and an eyepiece. If the purchase of these is made with care, a telescope will result that is capable of showing a great deal and of giving real enjoyment. Nor need such an instrument cost more than a matter of shillings, plus a little trouble in mounting the lenses in a suitable tube of any material, stiff enough to keep them in proper alignment. Since the cost is so small, and construction so simple, it would do no harm to make such an instrument, even if a more ambitious telescope were the ultimate aim.

The final choice as to size must be made by the prospective observer himself and will be governed by a number of considerations of a completely individual

nature concerning which it is impossible to give any advice whatever; these will cover such things as money, the site from which he intends to observe, and the amount of time available for the use of the telescope.

Taking these considerations into account, the facts to which we shall now draw attention should be of help in making a wise choice.

The first, then, is that the characteristics of the telescope are not all modified to the same degree with a progressive increase in size. Doubling, for example, the aperture of an object glass (or a mirror, in the case of a reflector) results in fourfold increase in the amount of light available for image-formation. It results also in an increase of "resolving-power" and the ability to separate close double stars and in the definition of lunar and planetary detail, but this time only a *direct* increase. The *resolving-power* of a four-inch telescope, quality for quality, is twice as high as that of a two-inch.

"Light-Grasp"—the Effect of Aperture

Light-grasp increases as the square of the aperture while resolution increases directly. For this reason it is necessary to go to considerable lengths in order to obtain a very great increase in resolving power—lengths which will quickly alter out of all recognition the owner's equipment, if he embarks on an indiscriminate programme. Unfortunately, doubling the diameter of a lens or mirror generally means doubling the length of the telescope also, and, since this leads to an eightfold increase of volume and weight, such doubling leads very quickly to the abandonment of any pretence of portability; such abandonment is wise. It is even more unfortunate that the increase also leads

to an, approximately, eightfold increase in the cost of construction and mounting—and not infrequently leads to the abandonment of the telescope itself while still in a half-completed form.

It is as well to consider very carefully just how large one's telescope needs to be. Many amateur instruments in use today are of such a size as would have made them seem quite exceptional instruments a few generations ago, and some of them are used for work which fully justifies their aperture. But if the telescope is to be used principally for the pleasure derived from mere casual observation it is likely that something of more moderate size will prove more effective. There are many who habitually use large instruments who are able to enjoy the more simple pleasures of ordinary stargazing, and for this purpose frequently use the smaller "finder" telescope attached to the tube of the main instrument, rather than the large one!

Virtues of the Small Telescope

The advantages of the small telescope are many; its ability to present large areas of the sky for the observer's inspection is altogether superior to that of the large instrument. It therefore makes rapid location of objects a simple matter and so it becomes an indispensable accessory to large telescopes. Used on its own, the wide field makes the simplest sort of hand-guiding entirely satisfactory and if its field of view be sufficiently large it requires no mounting and can be held in the hand. For instructional purposes, in particular, the value of low-power and wide-field cannot be over-stressed. In the first place one knows with certainty what one is looking at, and surprising though it may seem, the beginner with a large tele-

scope is sometimes not so certain of this; and, using high powers, even experienced users have been known to make gross errors of identification through slight misalignment of a finder or through mis-reading of the time or of the setting circles, owing to the extremely small *real* field of view, covering only a few minutes of arc, that really high-powers involve.

The "Richest-Field Telescope"

For general study of the Milky Way, which is itself a pleasure that ought to be enjoyed by everyone professing the slightest interest in astronomy, perhaps the best telescope of all would have an object glass little more than a couple of inches in diameter and would use a power no greater than 6x or 7x. Such an instrument is often described as a "Richest Field Telescope," or, simply, an RFT. It became so-called since it is the telescope which, when turned towards the Milky Way, will show more stars at a single view than any other telescope large or small. We shall return to the reasons why this should be so later on.

A pair of good 7x50 binoculars is an excellent instrument for this purpose. Apart from the light loss that arises from the use of the large prisms, they come close to being an ideal double-barrelled RFT. No owner of such binoculars has exploited them fully until he has settled himself, warmly clad, in a deck-chair, on a fine evening in late September, and explored, in comfort, the rich Milky Way star field of Cygnus. Let him try it at the first opportunity and ponder on what he is seeing. The so-called rift which can be so plainly seen to split the Milky Way into two branches for a very considerable distance, is one of the greatest of the Dark Nebulae to be found in our own Galaxy; the light from the countless thous-

ands of stars which lie beyond it cannot penetrate what we now know to be the vast cloud of dust and un-illuminated gas of inter-stellar space. Let him turn his binoculars on M.31—number 31 in Messier's unique list of red-herrings to be avoided by the seeker after comets—and, if the night is moonless and clear and free from the glare of city lights he will see the great ellipse of our own Galaxy's twin . . . the vast spiral galaxy in Andromeda. So distant is this enormous star system that the light which is focussed by his binoculars started on its journey nearly two million years ago when no such being as man had as yet set foot on the surface of our own world. The middle of the sword of Orion (θ Orionis) under the same conditions will show what happens when a cloud of cosmic debris such as that forming the great rift in Cygnus has very hot stars embedded in it; here is the Great Nebula in Orion, an aurora of unbelievably vast dimensions out of which stars are at the present moment being formed—stars which will not commence to glow with a brightness sufficient to reveal them to the unaided eye until long after the artifacts of our present civilisation are part of the archæological bric-a-brac of our remote descendants to ponder over if they wish.

CHAPTER V

War-Surplus Telescopes

AN EX-GOVERNMENT predictor "elbow" telescope is an instrument with much the same characteristics as the 7x50 binocular, but costing today very much less. It has certain advantages when applied to purely astronomical use. This instrument could hardly be considered in view of its enormously high cost of production, if it were not available as a war-surplus item. For a trifling sum compared with the cost of a pair of 7x50's one can obtain a 50mm. aperture "elbow telescope." This is essentially an 8x50 monocular employing a different prismatic system to obtain an erect image. Its specific advantages can be briefly listed; although the loss of light by absorption in the glass prism is similar to that in ordinary binoculars, there is a very considerable gain in light-transmission since the erecting-system makes use of a considerably reduced number of air/glass surfaces. This type of instrument is far more completely free from internal reflections than the conventional binocular; the eyepiece itself is of an unusual and expensive form, and the field-lens is combined with the prism, focussing being achieved by means of a helix which brings the achromatic eye-lens into the desired position. The result is an image presentation that is not only of beautiful quality itself, but remarkably free from "ghosts" even when turned on a bright object like the full moon or the planet Jupiter. Despite the modest magnification of the instrument

(8x) a quite surprising amount can be seen. Many lunar features can be identified by a practised eye, features whose known size emphasises that it is the quality of an image rather than size that is important for making details clear to the eye. Even with so small an instrument as this, the eclipse of Jupiter's satellites can be seen, provided they do not occur too close to the body of the planet. Using this telescope as an astronomical instrument, one cannot but wonder at the provision of such an outstanding optical system for the task for which it was originally intended.

Astronomical Use of the 8x50 Monocular

For the amateur astronomer a feature of great benefit is that the erect image is formed after the light path is turned through 90° ; thus, with the eyepiece at the side of the telescope it is possible to sweep across the sky from horizon to horizon without inclining the head. This makes possible prolonged observation of objects in the sky, even when directly overhead, without the slightest fatigue.

These instruments have been used with success by observers for even highly specialised purposes. On improvised mountings they have been proved of value for such varied applications as observation of the solar-corona during total eclipse of the Sun, and for the detection of telescopic meteors, i.e., meteors of insufficient brightness for naked-eye observation. Several enthusiasts have mounted these instruments in pairs to suit their own eye-separation, with their eyepieces uppermost, and thus made what must surely be the lowest priced 8x50 binocular one is likely to encounter. Since they are provided with a close fitting cover for the object glass and are made of non-oxidising material, only the most casual sort of pro-

tection is required when they are permanently mounted out-of-doors.

The Use of Magnifying Power

However fascinating the general picture of the sky that instruments of this type provide, their use must necessarily be limited in view of their relatively small magnification. For the star-gazer nothing more is required and he will undoubtedly derive more real pleasure from low-power instruments of the RFT type than from any other.

If it is intended to take advantage of the extremely low cost of war surplus material one must face the fact that all such instruments were designed to carry out supremely well one particular (and often highly specialised) task. Because of this, many of them are of the wide-field, low magnification variety. Where one's desire is for a telescope of higher power, one should consider those instruments whose original purpose lay closer to that for which the observer now requires them.

Reasonably detailed study of star-clusters and appreciation of lunar surface-features, and the projection of sunspots by the method previously outlined, will, for example, require more than this minimum magnification.

It has already been pointed out that, whatever the type of telescope, if the quality is really good the image must be magnified if the eye is to see *all* the detail that the image is able to reveal. Eyes differ very considerably in respect of the degree of magnification that they seem to require. No hard and fast rule can be made concerning the magnification that any particular object glass should be made to carry. The upper limit will be decided on the basis of experience

by the observer himself, and will depend upon the type of observation. For some special types of observation magnification that would be, in other kinds of work ridiculous and quite unjustified, can sometimes be used to advantage. Concerning the lower limit one can be more specific. For astronomical purposes one can rest assured that full advantage of the light-grasp of the instrument will not be taken if the magnification is less than about 3x or 4x per inch of clear aperture.

Magnification and Eye-beam

Even on a fairly dark night the pupil of the eye is unlikely to be fully dilated and will probably not be more than $\frac{1}{2}$ inch diameter. The beam of light which is presented to the observer's eye is of a diameter governed by the size of the object glass, and the magnifying power being employed. In fact, this beam is equal to A/x where "A" is the aperture and "x" is the magnification. Unless the value of A/x is no greater than the pupil-opening of the eye at the moment of observation, it is clear that the whole beam cannot enter the eye to be focussed upon the retina. In fact one is stopping-down, so far as light grasp is concerned, just as effectively as if the size of the O.G. itself had been reduced in diameter. Where any bright object lies within the field of view during an observation, it is likely that the iris aperture will quickly be reduced so that it is less than $\frac{1}{2}$ inch—perhaps very much less—and a higher power than 3x per inch of aperture will be required for full illumination of the field. It will be noticed that the 8x50 elbow telescope above mentioned makes use of an eyebeam $\frac{1}{4}$ inch in diameter (taking 50mm. as being the same for practical purposes as 2 inches). For this reason its

observer himself, and will depend upon the observation. For some special types of observation magnification that would be, in other kinds of observation, ridiculous and quite unjustified, can sometimes be used to advantage. Concerning the lower limit one should be more specific. For astronomical purposes one should be assured that full advantage of the light-grasp of an instrument will not be taken if the magnification is less than about 3x or 4x per inch of clear aperture.

Magnification and Eye-beam

Even on a fairly dark night the pupil of the eye is likely to be fully dilated and will probably not be more than $\frac{1}{8}$ inch diameter. The beam of light which is presented to the observer's eye is of a diameter governed by the size of the object glass, and the magnifying power being employed. In fact, this diameter is equal to A/x where "A" is the aperture and "x" is the magnification. Unless the value of A/x is greater than the pupil-opening of the eye at the time of observation, it is clear that the whole of the light cannot enter the eye to be focussed upon the object.

In fact one is stopping-down, so far as light-grasp is concerned, just as effectively as if the size of the O.G. itself had been reduced in diameter. Where the right object lies within the field of view during observation, it is likely that the iris aperture will be reduced so that it is less than $\frac{1}{8}$ inch—perhaps very much less—and a higher power than 3x per inch of aperture will be required for full illumination of the field. It will be noticed that the 8x50 elbow telescope above mentioned makes use of an eyebeam of 1.25 inches in diameter (taking 50mm. as being the same diameter for practical purposes as 2 inches). For this reason its

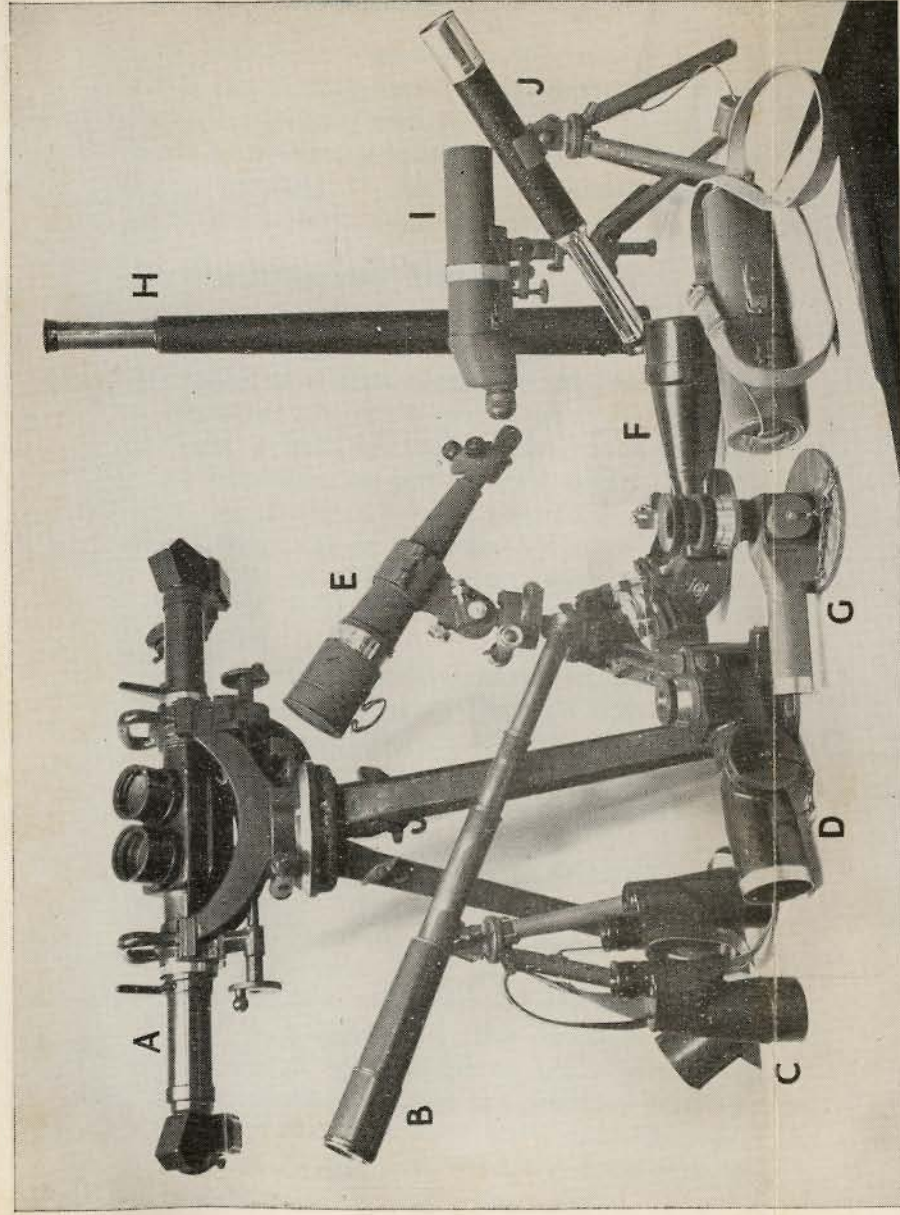

A few of the many types of observing instruments produced to service needs. Although designed for terrestrial observation they are generally of good quality and can often be put to good use by the amateur astronomer.

- (A) The Mark III Anti-Aircraft Identification Telescope for use by two observers. Further reference to this instrument is made on pages 30-32.
- (B) Three-draw telescope of approximately 25 x with O.G. diameter of 2 inches.
- (C) 7 x 50 binocular of Bausch and Lomb design.
- (D) Prismatic telescope made by Cooke, Troughton and Simms for aircraft observation. Magnification is approximately 8 x.
- (E) Triple-power telescope with powers of 15 x, 23 x and 30 x.
- (F) 20 x 70 prismatic telescope removed from the Mark IV Identification Telescope.
- (G) The 7 x 25 prismatic telescope by Cooke, Troughton and Simms. The $\frac{5}{8}$ in. focussing eyepiece in this instrument is of the Erfle Orthoscopic type.
- (H) One of the smaller coast guard telescopes with an object glass of $2\frac{1}{4}$ in. diameter.
- (I) The Bausch and Lomb type prismatic telescope approximately 20 x 56.
- (J) A Naval single-draw telescope of approximately 16 x magnification with O.G. diameter $1\frac{3}{8}$ in.

optimum performance on faint objects can be expected when the sky is dark and the iris-opening of the eye attains a diameter of $\frac{1}{4}$ inch.

It will be necessary to say more concerning optical principles involved in the use and construction of eyepieces in the later pages of this book.

Medium Power "Surplus" Telescopes

No standard military-type instrument is known to the writer that makes use of what the astronomer would regard as a high-power for the size of object glass embodied in it. Where such telescopes use what might sound, to the layman, a considerable degree of magnification one can rest assured that the objective has plenty of reserve power that, with careful modification, can be exploited by those who know what they are at. Even without such modification some of these telescopes possess qualities of considerable value.

One wartime military instrument of special value to those who enjoy sharing their pleasures, and to teachers, is the anti-aircraft identification telescope. This is essentially two complete telescopes assembled on the same mounting, one to give an extremely bright image and a wide field of view, and the second a "close-up" of the central portion of this field of view.

For the teacher the advantage lies in the fact that the low-power component can be used as a "finder" as well as for wide-field views of the sky, while the observer, or student, at the second eyepiece, enjoys a considerably magnified view. For instructional purposes the uses of the instrument are obvious. Both units of this double-telescope are provided with prismatic erecting systems that turn the light path through a right angle, and what has been said con-

cerning the predictor type elbow-telescope applies here also; the lack of fatigue after prolonged observation of objects at high elevations is more easily appreciated by those with experience of less convenient forms of telescope, but others will no doubt discover its advantages also.

These instruments are provided with an azimuth scale calibrated in degrees, and numbered at ten-degree intervals, and with altitude scales; the azimuth circle is, in both cases, large, and easily read. Both the horizontal and vertical axes of these instruments are of robust construction, and smooth rotation is obtained by means of enclosed worm gears. The ruggedness of the mounting makes it a simple matter to adapt them (by setting-up with their vertical axes tilted and directed to the celestial pole) so that they can be used as equatorial type instruments. Set up in this way the telescope, once directed towards an object, can be made to keep it in view by rotation upon the polar-directed axis alone, so long as the object remains unobscured and above the horizon. In the "double-telescopes" the geared azimuth movement incorporates a reduction of 80:1, and the addition of a mechanical drive, by means of a suitably geared small synchronous motor, is all that is required to convert the mounting into a "clock driven" telescope, well able to carry a camera weighing several pounds; while the higher power eyepiece is employed by the operator for guiding purposes. Provision can easily be made for such a camera to be positioned permanently and invariably with its optical axis parallel to that of the two visual telescopes.

The wartime function of these instruments was to assist in the identification of approaching aircraft—

a use requiring high optical quality and definition comparable to that required in some classes of astronomical work. Object glasses obtained from these instruments have been known to perform very well on astronomical subjects when remounted in more simple form. Magnifications, with suitable eyepieces, up to 120x have been obtained without any serious deterioration in the image quality. One case is well verified, in which a telescope made with one of these object glasses mounted on the tube of a large equatorial, and fitted with a polaroid eyepiece-filter, easily revealed four principal cloudbelts on the planet Jupiter, in full sunlight, on a midsummer's afternoon. This is remarkable testimony to the quality of an object glass only $2\frac{3}{8}$ inches in diameter—and one which had never been intended to meet such rigorous demands.

Naturally, such performance cannot be expected from the telescopes in their original form, in which the limit of power is 30x; it does suggest, however, that the acquisition of such a telescope provides an opportunity for future experiment, that might well reward the owner, if he should decide to undertake the modification of the instrument. Should the object glass alone, from a dismantled instrument of this kind, be available, it would be an exceedingly worthwhile acquisition.

CHAPTER VI

What Type of Astronomical Observation?

SO FAR, the instruments we have discussed have, with the exception of the simple non-achromatic type put forward as a worthwhile home-built telescope, been of a particular type. Essentially, they are, with this one exception, *erect-image systems*, and, while they can be used with advantage by the amateur astronomer, are suitable for terrestrial observation. Their limitations in this latter respect should not, however, be overlooked; these arise not from their optical systems, which are of fine quality but from the weight of their housings. While they are all portable, in the sense that they can readily be moved from place to place, they are not suited to the needs of those who require to carry a telescope long distances, perhaps while walking or cycling, and who feel that the application to astronomical objects will be only a very minor part of their usefulness.

Binoculars and Field Glasses

Many people with no more than a casual interest in the sky at present have felt the need of an instrument, not so much for serious study, as to show them something of what they would like to see; but they feel that the expense of specially equipping themselves with an article of such limited use cannot be justified. Binoculars, it is true, do have a wider use, but they are not the type of thing one buys casually and without a second thought; certainly not when they are 7x50 prismatics of the kind mentioned early in

WHAT TYPE OF ASTRONOMICAL OBSERVATION ?

these pages. There are however, plenty of binoculars, ranging from 6x25, including ex-Service and surrendered ex-Wehrmacht varieties, that can be had fairly cheaply. There are also non-prismatic field-glasses the virtues of which have already been mentioned. These last do need to be good, really good, if they are to be of much use even for occasional astronomical observations. The sad thing is that they should vary in quality so enormously. The best field-glasses are extremely good and have well-figured achromatic object glasses of large aperture and properly computed achromatic eyelenses as well. Such instruments, especially when they are in good mechanical shape and of naval pattern, can generally be purchased with confidence; but it must be expected that the magnification will be small. Even with large object glasses a power of more than about 3x will entail a restriction of the field that can hardly be welcomed.

Terrestrial Hand-Telescopes

If extreme portability and lightness are regarded as indispensable, and if binoculars are too expensive, or provide insufficient magnification, there remains an alternative, in the telescope designed to be held in the hand and giving a power generally in the region of 16x-20x. Let it be clearly understood that such telescopes are rarely of what is regarded as "astronomical quality." Even so, they most certainly fall into the class of instruments which can be termed "useful." They will certainly reveal a great deal that no unaided eye could detect and (if reasonably good) more stars than many people are aware even exist. In addition they can be brought to bear on an object almost as easily and quickly as the eye itself. In their lightest form they are as portable as a

thermos flask, and can be taken on any expedition where this would not be considered an encumbrance. There can be little doubt that many who read these words will have first come to take an interest in astronomy through using just such an instrument on the sky, for no other reason than that they happened to have one. The fact that they are primarily meant for the enjoyment of distant terrestrial views need not deter the keen town-dwelling astronomer from becoming the possessor of one. Their value as an auxiliary instrument is perhaps best appreciated by the amateur astronomer when he finds himself in the country, perhaps in the mountains, at night—when to his unaccustomed townsman's eye the sky is a blaze of stars. A humble terrestrial telescope, light and easily passed from hand to hand can then be a boon indeed. Amateur astronomers are notoriously anxious to share their special joys, and the portable terrestrial telescope, on holiday jaunts, has often been found a valuable means of conveying to others something of the pleasures that can come from observing a display which, without some form of telescope, must remain unseen.

The Astronomical Refractor

What of the amateur observer who has exploited to the full the capacity of instruments of the order of size that we have so far dealt with? And what of the newcomer who is convinced of his capacity and inclination for work of a type requiring a telescope of considerably larger size?

Astronomical telescopes, pure and simple, are available, and the sizes range from the humble two or three inch aperture refractor on a simple tripod mounting, up to those of five to six inches. A

refractor even as large as a five inch is nowadays an expensive article by any standards whatever. Mounted as an equatorial with such accessories as it deserves it would be outside the range of those for whom this little book is intended.

Occasionally such telescopes become available at second hand; even then they are liable to cost more than most enthusiasts can afford to pay. In addition to the problem of purchasing anything as large as this, the problem of housing the instrument arises. At least one six-inch refractor is known that is removed from its mounting after every set of observations and packed away indoors in its transit-case. Generally speaking, *no refractor of ordinary focal length can be considered portable when it exceeds about four inches in aperture*. Consider that a six-inch "normal" astronomical refractor is approximately 90 inches in length, that it weighs—tube and "optics" alone—probably 30 to 40 pounds, and that it must be poised at the top of a tripod seven or eight feet high, and you begin to appreciate the problem of nightly setting it up, and the even more depressing problem of stowing it away, perhaps very late at night, after a heavy dew or in a sharp frost. A standard make of four-inch telescope of a fairly simple, tripod-mounted, variety can cost more nearly £300 than £200. Second-hand three-inch telescopes are frequently offered at anything from £17 to £40, depending on quality and general condition. If mounted "equatorially" these figures are likely to be more than trebled. The quality varies considerably, and performance, too, can be very different as between one telescope and another of the same aperture. It is as well when purchasing anything so expensive as a refracting telescope to be sure of its quality.

CHAPTER VII

Mounting Problems; Astronomical "Seeing"

WHERE the telescope must be large, there is little doubt that the reflecting telescope is the instrument for the amateur. Even then, many of the considerations regarding light-grasp, resolution and cost, need to be taken very much to heart if frustration is not to result. It needs to be stressed that, to perform effectively, the mounting of a large telescope is every bit as important as the optical part of the instrument.

Mounting a large and powerful telescope so that it can be smoothly and steadily rotated to counter the earth's motion and keep a star or planet in the middle of a necessarily small field of view is a problem not always as simple as it might seem. Few people have the facilities for machining large and intricate castings and when recourse is had to outside help the cost is apt to rise alarmingly; so, too, is the time the telescope takes to get anywhere near completion. And such a mounting must not only be strong; its strength must be *inflexible*. This is not always understood even by people with sound experience in more commonly met engineering problems. The higher the magnifying power used at the telescope the more wearing will be the effect on the observer of the slightest quiver of the telescope tube or of the mounting, since such movement will itself be magnified correspondingly. It can safely be stated that any vibration in the telescope that can be detected by the fingertips on some metal part of the mounting under conditions

(of wind, etc.) resembling what might exist when the telescope is in use, will render it completely unusable as a photographic instrument.

Nevertheless many amateurs *have* mounted their telescopes themselves, though with extremely varying degrees of success. Astonishing things have been achieved by the most simple and primitive means; ugly, ungainly contrivances involving, quite literally, railway sleepers, considerable masses of concrete and back axles from heavy trucks, have sometimes performed admirably, combining a rocklike steadiness with a smoothness of rotation that nothing could better. These qualities have to be paid for in some way, either in money, appearance, or time, and a good deal of personal work, and the exercise of ingenuity amounting in some cases almost to genius.

Atmosphere and "Seeing"

When we come to really formidable telescopes such as those often used by specialists in lunar and planetary work, we must appreciate that they are more sensitive to atmospheric conditions, and are apt to suffer more noticeably when seeing conditions are poor. Many observers have discovered that a small telescope will frequently match the performance of a far larger one owing to the large instrument's susceptibility to "bad seeing," and that large aperture is far from being an unmixed blessing. The reasons for this susceptibility can be understood if we examine the demands that a large telescope makes on the atmosphere at the time of any particular observation.

To some extent we have to regard the air that lies between the telescope and the object viewed as part of the optical system. Like glass, air has the property of refracting light. And, just as light is refracted in

passing from one medium, air, into another medium, glass, so it will suffer some degree of refraction at every passage from air of one density into air of another density. The careful and continuous stirring that takes place during the cooling of optical glass until its viscosity is completely uniform, is necessary to ensure that the glass shall be of sufficiently uniform density. Without such treatment the refractive index of the glass would vary from square-inch to square-inch. Even with such treatment only a small amount from any single melt proves, as a rule, to be suitable for the most exacting requirements. Such stirring as takes place in the atmosphere is a good deal more haphazard and rarely attains the highest optical standards; when it does, seeing conditions are superb, and a fine instrument will then do full justice to its maker. The violent scintillation, and even changes of colour, that can be conspicuous in stars close to the horizon, even when viewed by the naked eye, are evidence of the constantly varying relation of layers of air of different density in the narrow cylinder of the material that is illuminated between the pupil of the eye and the upper levels of the atmosphere in the direction of the star. If such a small-diameter "air-lens" contains so many varying inequalities, how can we expect that one embracing 1,600 or 2,000 times as much of the same material will do any better? Yet this is expected of a telescope that makes use of a ten-inch light beam! Even when conditions seem good to the user of a small telescope, they may be disappointingly poor for the owner of a large one and evidence of this can be found in the care which is taken in the siting of really large observatory instruments. Clean air and clear skies are only part of the problem. Many parts of the world can provide

both these facilities, but the places where air of good optical quality is usual are few and far between. The surprising thing is that so much useful work can be done with large instruments. A fair way of summarising the position is as follows; even though it is rarely permitted to perform at peak level, conditions will often be such as to allow a fairly large telescope to perform well. Moreover, seeing conditions are rarely quite stable except when they are occasionally first-class. Even in very moderate or perhaps poor conditions this instability gives odd moments when something like the full power of the instrument can be appreciated. Everyone who has used a telescope of more than a very few inches in aperture has experienced the sudden flashes of absolutely sharp definition of almost incredibly minute detail that sometimes occur during the most disappointing observations and the trained observer soon comes to regard this as being the natural state of affairs and is ready to take advantage of such glimpses.

As an encouragement to those who may have been unduly depressed by the foregoing remarks let it be stated that, even in Britain, conditions are by no means always bad; they are frequently poor, often reasonable, and *sometimes* very good indeed.

What conclusions are to be reached in view of these facts? Is there some kind of mean—a telescope big enough to be useful for almost any sort of work the amateur is likely to undertake yet not so big as to present him with overwhelming problems of mounting etc.; and not so big as to be usable to best advantage only on the most rare occasions? Any such "mean specification" can be only loosely applied and much will depend on factors not so far taken into

account. Such factors should include local observing conditions; the amount of sky available from a single position will do much to determine whether the telescope must retain some degree of portability. If so, the aperture will be restricted if the completed telescope and mounting are to have the necessary robustness in relation to size that was stressed as being of such importance a few pages ago. Any proximity to a large industrial town, especially if the direction of the prevailing wind is such as to pass over it in the observer's direction must be expected to limit severely the number of occasions on which high performance can be expected from a telescope of any very great size.

For most applications a telescope of six inches is the one that probably gives the best general solution for the observer who wants an "all-round" telescope able to give fairly high power while still, if properly designed, retaining many of the desirable features of the really small telescope, such as low-power views of rich star clusters. The comparative ease of mounting it either as a permanent assembly or on a moveable tripod should not be overlooked. It is some comfort to know that, while a six-inch refractor would be of quite prohibitive cost, reflectors of this size are in constant use by many hundreds of observers not only in this country but all over the world. The results obtained in a great variety of astronomical work are testimony to the capacity of the instruments of this size when they are of good quality and are in the hands of those who know how to use them to advantage.

CHAPTER VIII

The Amateur's Newtonian Reflector

FOR a great many years the six-inch reflector has been considered to be *the* telescope for amateurs. It may be of interest, therefore, to take a special look at such an instrument and see just what it has to offer.

To apply the same standards of perfection that we used in discussing the capacity of a one-inch aperture telescope: we find that a six-inch reflector with optical parts of good quality, equipped with suitable eyepieces, and *properly mounted*, will show under the best conditions, lunar craters down to about $\frac{3}{4}$ mile in diameter. Good atmospheric conditions, plus clear sky, and high contrast, will also result in the detection of many delicate features on the Moon's surface. Some of these features, frequently observed by users of such telescopes, are known to be of a size that theory would suggest to be incapable of resolution. When this happens it would be unwise for the observer to suppose that what he sees represents the true and final form of the feature; sometimes this evident resolution is spurious, being the result of overlapping in the very complicated diffraction pattern which the imaging of areas of high contrast by optical means must involve. A microscope will illustrate such points more clearly, and demonstrate how such spurious appearances can be completely modified, or possibly eliminated by use of higher aperture objective. All the same, it remains a fact that excessively fine detail,

especially when of a linear type, *can* be seen—and verified by larger telescopes on favourable occasions. Another way in which subjects below the resolving power of the telescope can be detected on the surface of the Moon is by detection of the shadows which they cast under low-angle illumination by the Sun. Then it is that very narrow ridges of no great height can be seen thrown into exaggerated relief, in much the same way as every small unevenness of a reasonably smooth road is exaggerated when seen illuminated by the headlamps of an oncoming car.

Effect of Aperture—Lunar Detail

There are many observers who find the pursuit of minor features of the lunar surface a fascinating occupation and, for this, the owner of a six-inch reflector is well equipped. His instrument will provide a very different view of our satellite from that enjoyed by those with smaller instruments. The Moon is, in fact, the object likely to reveal the difference in resolving power between this and lesser instruments most dramatically.

The reason is not far to seek; the multiplicity of craters, clefts, ridges and valleys that make up the lunar landscape come in all sizes; particularly is this so of craters. Just what the lower limit of size of these happens to be, no one can say with certainty; it is enough to remark that even the greatest telescopes in existence reveal minute craterlets down to the limits of their resolving power. As might be expected the smaller craters outnumber those of greater size, and every increase in aperture will, in the right conditions, bring into view increasing numbers of them. Sometimes a few inches increase in the size of the object glass or mirror will bring into view a whole

class of small craters, perhaps several hundred, just too small to be seen for what they are through instruments of lesser size.

Star-Brightness and Telescope Size

To some extent the same thing happens when the telescope is turned towards the stars; the number of stars increases very rapidly as one passes from the very brightest stars down to those only just visible to the naked eye. The same process continues well into the telescopic range and a minute telescope able to show stars only a single magnitude less bright than those that the unaided eye can see would result in the doubling of the number of stars observable. However, as the telescope increases in size this acquisition of more and more stars begins to decelerate. To gain a single magnitude of stars requires that the lightgrasp of the telescope be considerably more than doubled; in fact the object-glass diameter will need to be increased by somewhat more than 50 per cent. So it is a simple matter to double the number of stars visible if our starting point is the number revealed by eye alone! A half inch object glass will be ample, and allow us to waste a good deal of its light with a thoroughly ill-selected eyepiece, and perhaps a certain amount of dirt on the lens too, and yet see twice as many stars. Supposing we already have the good fortune to possess a twelve-inch telescope, we shall have to scrap it and build ourselves one that is not far short of 20 inches in diameter in order to gain a single magnitude!

Moreover, the new "giant" telescope will by no means show double the number of stars that the twelve-inch was able to reveal; and larger and larger telescopes would confirm us in our conclusion that star-grabbing of this sort is a luxury that one can

well dispense with, unless essential to the line of study that one has adopted.

The reason is that while there are twice as many stars of the fourth magnitude as there are of the third, there are by no means twice as many stars of the fourteenth as there are of the thirteenth. Even so the advantages can sometimes be striking when a telescope of moderate aperture is changed for one of greater power; even the gain of *part* of a magnitude can lead to a new appreciation of objects like the globular clusters. These satellite star-systems lying at great distances outside the galaxy are among the most fascinating objects the sky has to offer; a truly large telescope will resolve them so completely that they can be seen as incredibly tight groups of stars—each group containing many thousands. In a small telescope they seem to be no more than a single, far from bright, star with a faintly nebulous appearance.

As optical power goes up, a sprinkling of stars minute but quite sharp and distinct, appears on this nebulous background. By the time one reaches an eight-inch telescope the cluster is, so far as the nearer ones are concerned, fairly well resolved, so that the nebulosity that remains is not readily noticeable, and the globular cluster will show many hundred needle points of light, every one of them a remote sun, its brilliance so diminished by distance, that even the tight cluster comprising thousands of these suns appears as a single, rather weak, star to the eye without a telescope.

Yet such distances cover only that tiny corner of the universe filled by our own galaxy and its immediate surroundings. The sky is filled with evidence of the overwhelming size of the universe, and no doubt

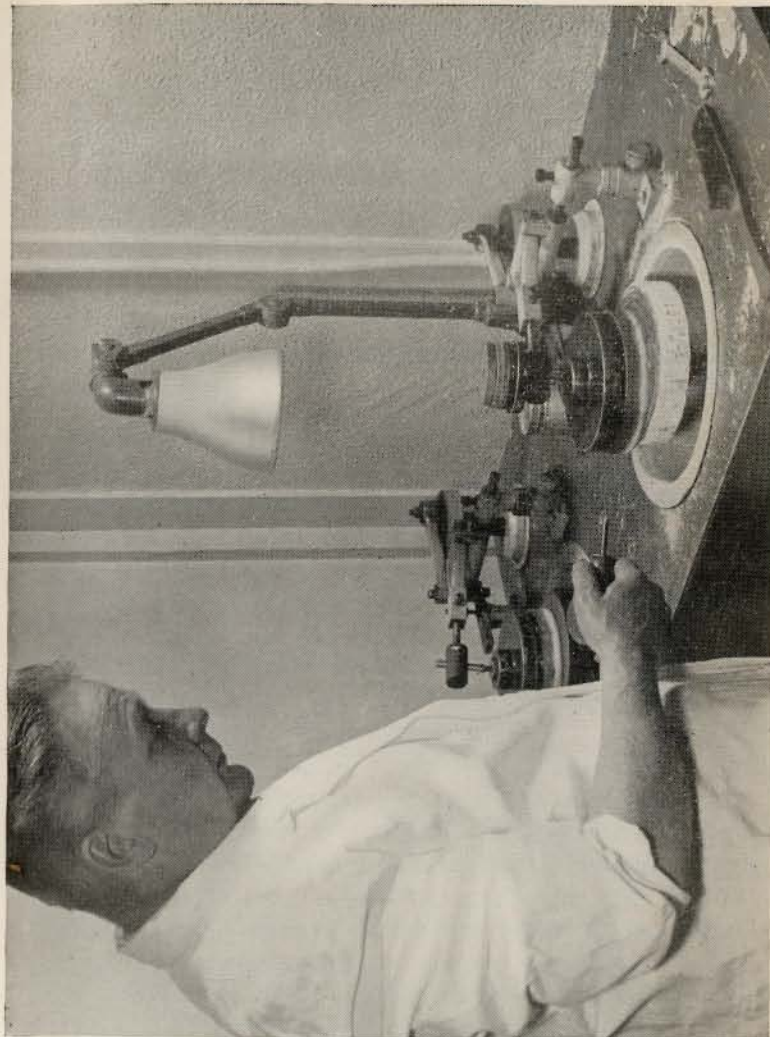

A six-inch mirror for a Newtonian Reflecting Telescope being polished to the spherical stage on a Bryant and Symonds type Surfacing Machine prior to parabolising by hand.

(Photographed in the Optical workshop of Charles Frank).

the new owner of a six-inch telescope will spend many hours filled with wonder and astonishment, as well as pleasure, in taking his fill of what his telescope has to offer, simply stargazing, without a thought of making any personal contribution to astronomy.

Naturally, the usefulness of this telescope and the enjoyment derived from it will be greatest when the instrument is designed to make the best use of the quality of the mirror, which should be as high as possible.

Spherical Aberration

The large mirror takes the same part in the reflector as that taken by the object glass in a refrac-

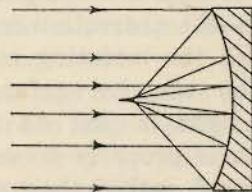

Spherical Aberration—uncorrected spherical mirror.

tor. Should the concave surface of the mirror have a spherical curvature, the rays from a star which are reflected from the outer zones of the mirror will arrive at the optical axis at a point nearer to the mirror surface than the rays which are reflected from the centre of the mirror. If the mirror happens to be of relatively short focus—as most mirrors are, compared with a standard type of object glass—this “spherical aberration” will be gross; the image will be distributed in *depth* along the optical axis and there will be no true focus. With the eyepiece focussed to the best possible advantage, that is to say on the plane where concentration of the rays is greatest, the circle enclos-

ing them will still be large; there will still be a great amount of light out of focus. This is analogous to the case we discussed concerning the non-achromatic object glass. With the reflector, such severe spherical aberration as we are considering would, however, be far more damaging. When the distribution of light that should be forming an image is spread along the axis according to colour, the eye immediately finds the focus of those rays to which it is most sensitive—in the yellow-green region of the spectrum. The out-of-focus rays such as the blue and the violet, although they might be disastrous photographically, are not particularly obtrusive where the eye is concerned, so that the image remains relatively sharp. In the case of the *mirror* the selection of focal position has nothing to do with colour—the aberration results simply from the angle at which the incoming rays from the star or planet strike the reflective surface. In other words, the out-of-focus light is just as noticeable to the eye as that which is properly focussed; star images appear to be “blobs” rather than points, and where the aberration is extreme the mirror will be quite useless. In cases where this fault is moderate, the mirror's performance with a really low power eyepiece (one having a great depth of focus) will appear to be quite good. But as soon as a more powerful eyepiece, having very little depth of focus, is applied, it will be found impossible to utilise more than a portion of the light returned towards the eye by the mirror—and the mirror will be found to be completely hopeless if still higher power is applied.

The “Figure” of an Astronomical Mirror

Apart from considerable complication of the optical parts of the telescope, there is only one way

to overcome this trouble—by ensuring that the curvature of the mirror surface is such as to return all the rays from the centre of its field of view to a position where their distribution along the axis is no greater, and preferably a good deal less, than the depth of

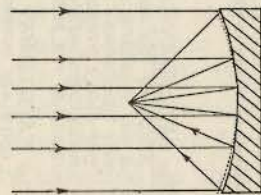

Spherical Aberration eliminated by "figuring" mirror to paraboloidal form.

focus of the highest power eyepiece likely to be used. There is only one curvature that will do this; the curvature of a paraboloid.

Thousands of mirrors must have been made by amateurs (and are in many cases in use) in which any resemblance to a true paraboloid lies only in the owner's imagination. Others have produced sound and workable mirrors, and there is absolutely no doubt at all that some very fine mirrors have been produced at the very first attempt by a fair sprinkling of amateur optical workers. The surface must also have a proper optical polish if it is not to result in loss of contrast through light-scatter. A slight dullness, arising from incomplete polishing of the glass surface, will not *disappear* when the mirror is aluminised—it will in fact become more glaringly apparent.

Function of the “Diagonal”

Now refer to the diagram on page 48 and assume that the mirror at the base (the right) of the tube is a

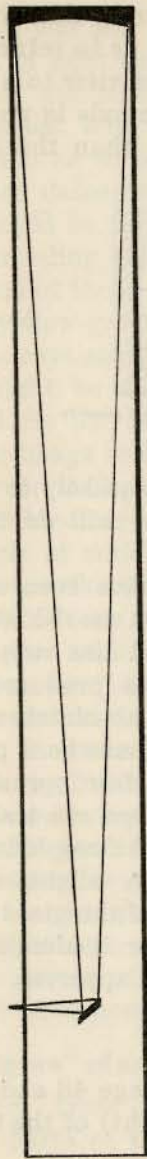

COMPOUND REFLECTORS

A FAIRLY STANDARD
NEWTONIAN TELESCOPE (top)
COMPARED WITH TWO COMPOUND
INSTRUMENTS—ALL THREE
TELESCOPES SHOWN HAVE
IDENTICAL EQUIVALENT
FOCAL LENGTHS.

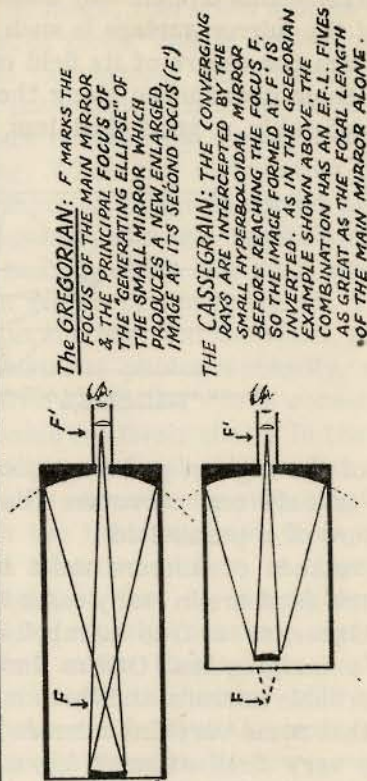

The GREGORIAN: F MARKS THE FOCUS OF THE MAIN MIRROR & THE PRINCIPAL FOCUS OF THE "GENERATING ELLIPSE" OF THE SMALL MIRROR WHICH PRODUCES A NEW, ENLARGED IMAGE AT ITS SECOND FOCUS (F')

THE CASSEGRAIN: THE CONVERGING RAYS ARE INTERCEPTED BY THE SMALL HYPERBOLOIDAL MIRROR BEFORE REACHING THE FOCUS F, SO THE IMAGE FORMED AT F' IS INVERTED. AS IN THE GREGORIAN EXAMPLE SHOWN ABOVE, THE COMBINATION HAS AN E.F.L. FIVES AS GREAT AS THE FOCAL LENGTH OF THE MAIN MIRROR ALONE.

perfect one. The rays from our central star will come to a focus in the centre of the mouth of the tube where they will form an image. This is called the prime-focus. A photographic plate of small size could be suspended here to take a photograph, but for visual observation it is necessary to divert the converging cone of rays so that the focus is formed to one side, and outside the tube, and can be examined with an eyepiece. This is done with the help of a small aluminised plane-mirror or by means of a right-angled prism. In either case this secondary optical surface has to be suitably mounted so that it is rigidly held without tremor, and at the same time, without its supports causing any unnecessary obstruction of the light coming towards the mirror from the star: although neither the size of the flat nor its supports should cause much concern on this score.

The loss of light falling on the centre of the mirror, occasioned by the shadowing effect of the flat, is so small that it can safely be ignored. This is the case even when the secondary mirror or prism is of quite considerable size. Its most important effect is to cause a modification of the diffraction pattern formed at the focus by the reflected light of the star. This modification is by no means offensive, and its most noticeable feature is, in the case of a four-armed supporting system, to make bright stars in the field of view show four noticeable "spikes." This effect can be well seen in many of the beautiful photographs published by the great observatories of the world, and will also be found reproduced in many popular books on astronomy. It can be taken as a certain indication that such a photograph was taken with a reflector-type instrument.

From a practical point of view, then, let us ignore the remote possibility that our flat, or prism, is likely to be so large in size as to damage seriously the definition of the telescope. What will be the effect of a flat that is *too small*, and what size should it be? If full illumination of the whole field of view, obtainable with the lowest power of eyepiece likely to be employed, is to be attained, the flat must be of a size that will intercept the entire cone of rays bounded by the extreme edge of the principal mirror and the extreme edge of the field of view. If the telescope is being used photographically the plate (or at any rate the "frame") will suffer vignetting unless the same conditions apply. The result of vignetting, in both visual and photographic work with the telescope, is to make the apparent magnitude of stars in the centre of the field assume a greater value relative to those nearer the margin than is really the case. To the eye, which is not a particularly sensitive photometer, the effect of vignetting through having a flat undersize is often not evident; it would be glaringly apparent only in the most extreme case. Yet for some types of serious amateur astronomical work the fault would be such as to reduce very greatly the value of the observer's contribution; the fact that its effect would not be consistent would make it only the more insidious.

Vignetting

Let us take a typical case of vignetting and apply it to a telescope being used for the observation of variable stars. We will assume that the observer is experienced and of sound judgment and that normally his estimates of brightness are sound and reliable. As soon as he has to make a comparison between a vari-

able and a "comparison star" whose separation makes necessary the use of his really low-power eyepiece the trouble is likely to arise. Even if he tries to the best of his ability to place the two stars at equal distances from the centre of the field a slight departure from equality will result in a false comparison. Normally one would have a series of stars in the field of view to assist in the estimate of brightness of the variable, and the stars used for the purpose would be fairly close in terms of brightness, offering a series of "steps," so that a true estimate could be formed. If the vignetting were severe such stars would show their true brightness only if they lay near the middle of the field—all others would be false signposts and unreliable observations would be likely to result.

To be on the safe side, it is as well to make the flat large enough, and add a little (say, at least $\frac{1}{8}$ inch) as a reserve. Naturally enough this size will be determined by just how far up the converging cone of light it has to be placed. Reference to the diagram will show that the flat can be sufficient and still kept down to a reasonably small size by careful design. Make the telescope in this form, with the focal plane as reasonably close to the main tube as possible. The flat will then be the smallest compatible with that particular instrument—consistent with full illumination of the entire field of view. If it is felt that the instrument might at some time in the future be used as a *camera*, "field of view" should be read as "frame-size"; this need not be more than a 25mm. or 30mm. square on 35mm. film. Such a demand is by no means very great, and, since only a piece of film and not the eye itself has to be placed close to the tube, this could well be practically in the same plane as the

tube wall. If the flat is mounted so as to permit a certain amount of adjustment to bring it to a new position on the optical axis further from the mirror, it can still be of reasonably small size.

CHAPTER IX

Astronomical Photography for the Amateur

A PERFECTLY polished and figured astronomical mirror, with the surface film in good condition is a highly efficient photographic objective. It will prove to be a good deal "faster" than a lens of the same size and f/number. When the surface is aluminised it is the most highly efficient ultra-violet photographic instrument and permits the photography of objects invisible in light of "ordinary" visual wavelengths.

Amateur instruments of this type are commonly around f/8, and it will be found that any deterioration in image quality, even at the very edge of a 25mm. field, which is traceable to inherent weaknesses of the optical system (chiefly an aberration known as coma) will cause the amateur star photographer no distress.

Stability Requirements

It is no part of our task to go into details of design of accessories suitable for converting the 48 inch long amateur's telescope into a camera of four feet focal length. Those who wish to do so will in most cases be able to work out for themselves simple attachments suited to their purpose; and they really can be very simple indeed.

Far more important than any elaboration of focussing, etc., is the mounting of the telescope itself. If there is the slightest chance that the telescope might at some time in the future be converted in this way, special attention *must* be given to the stability of the mounting.

A 25mm. square negative will, with a six-inch $f/8$ objective, cover considerably more than one square degree of sky—and is large enough to cover, and more than cover, even the very largest galactic clusters, nebulae, etc. Of the great Nebula in Andromeda only the outlying parts would fall outside the edges of a plate of this size centred on it; moreover it should be remembered that adequate exposure on a suitable plate will record a greater area than would be seen by eye with the same telescope.

If the telescope is ever to be used for this kind of purpose, complete smoothness of rotation *must* be ensured when the mounting is made. Bearings should be as large and well finished as possible. Even if not provided from the first, the design should permit the eventual fitting of suitable gearing so that the telescope can be turned by mechanical or electric power. If the telescope is well balanced the power-demand is extremely low; the instrument will need to rotate at the rate of a single revolution a day on its polar axis. Since armature speeds of electric motors are so much higher than this, it can be appreciated that, even allowing for frictional loss in the gearing, the "power plant" can be of a most modest size. Electric gramophone motors have frequently been used. Even a weaker drive than this can be used with the assistance of weights, so that the contribution of the "drive" is one of regulation of speed rather than the supply of turning power.

Increasing the Image Size

In order to obtain a larger image scale than a six-inch telescope yields, it is possible to modify the telescope for photographic purposes, and to good effect, simply by adding a Barlow lens to the "camera attach-

ment." Suitable lenses can often be obtained at very low cost on the second-hand market. The telenegative component from an old-style telephoto lens is excellent for the purpose and those of Goerz are specially favoured. These are frequently of 75mm. negative focal length, and the Voigtländer 80mm. is also very good indeed. The latter is a cemented triplet; both forms can also be used as additions to the telescope for visual purposes.

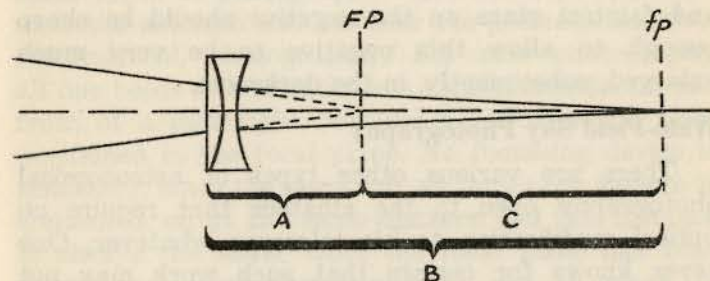

Action of the Barlow Lens

Placed a short distance within focus, the negative lens has the effect of refracting the converging rays so that they are made to take a path less steeply inclined to the axis. The result is to produce a new focus at a greater distance from the mirror. The effect of this is a larger scale of image, as though the length of the telescope had been very considerably increased. If the lens is of such a power that putting it two inches within the prime focal plane results in a new focal plane four inches behind the first, the *effective focal length of the telescope will have been increased by a factor of three*. Our telescope, of 48 inches length, will now be a photographic "long-tom"—with an image scale equivalent to that of a twelve-foot telephoto lens. The "speed" will be affected

when the telescope is used to photograph nebulae and extended surfaces of faint illumination; but not when it is used to *photograph stars*. Properly focussed in the new position, the plate will record a star cluster in the same period as before and on a scale, of $\times 14!$ Since no modification of the flatsize is necessary, it also becomes possible actually to use a far larger size of negative. What previously filled a 25mm. frame will now fill a plate 3 inches \times 3 inches. If the sky is clear and the guiding good, the images of the smallest and faintest stars on the negative should be sharp enough to allow this negative to be very much enlarged, subsequently, in the darkroom.

Wide-Field Sky Photography

There are various other types of astronomical photography open to the amateur that require no optical modification to his telescope whatever. One never knows for certain that such work may not result, almost by chance, in the obtaining of a record of real value to astronomy but it is safe to say that such considerations have little to do with the appeal it has for the amateur. As a rule the results have a value that is almost entirely personal; there is undeniable fascination in having one's own personal record, taken by the owner himself with his own equipment.

Such work as can be undertaken successfully by the amateur falls into several different classes. Some may be valuable and may provide supplementary evidence concerning something already photographed, perhaps with very different equipment at "full-time" observatories. In this respect the photographer of meteors and meteor spectra must be held in special regard. So, too, must the photographer of comets

whose efforts can hardly fail to be appreciated by his brethren when projected upon the screen at astronomical meetings—often well in advance of the release of photographs from "official sources." Then there is photography of the planets, the Sun and the Moon. This will mostly be undertaken with the aid of the telescope itself, probably with a lens to increase the plate scale, as already mentioned.

The equipment so often used with success for the other types of photographic work is frequently such as would astonish and bewilder the professional, non-astronomical, photographer. For star photography all one needs is a suitable lens rigidly mounted at the front of a light-tight box and a photographic plate positioned in the focal plane. No focussing device is necessary, since the stars are, as far as the camera is concerned, all at the same distance and this distance is always the same. Once the focal plane has been determined, permanent provision can be made to ensure (a) that the plate is invariably held so that it must be "square on" to the lens and at the proper distance from it and, (b) that it cannot possibly move about during the making of the exposure. Nor is any shutter necessary—or, at least, none more elaborate than an old hat to hang over the lens before starting and after completing the exposure.

Unless one is specially concerned to obtain lenses suitable for some very specialised purpose, the choice of lenses that the amateur can make from any well-stocked establishment dealing in second-hand photographic equipment is very wide; many suitable lenses are, to the more conventionally minded sort of photographer, almost in the "junk" class.

The fastest modern photographic emulsions are so fast that many of them can result in an amateur

sky photograph that could have been matched a few decades ago only by the use of extremely fast (and expensive) photographically corrected astronomical lenses.

As an example, photographs of Milky Way star fields showing stars further down than 11th magnitude have been obtained with an old portrait lens just over $2\frac{1}{2}$ inches in diameter and more than 80 years old. Such photographs require exposures considerably less than 20 minutes.

The definition of this type of lens (Petzval) over the central portion of the field is exceptionally fine. Even when the plate is considerably magnified, multitudes of fantastically minute star images can be seen. Negatives of this type can be made by anyone with a little skill, a little patience and sufficient interest, and they can, of course, be printed in a greatly enlarged form.

Lenses much smaller than this can be used although the plate scale should be sufficient to allow reasonable separation of the brighter stars in the field since prolonged exposure results in these forming far larger images through irradiation of the emulsion. When plates are used (and they are preferable to film in any but the smallest of sizes) they should be "backed" or, especially where there are many bright stars in the field, halation will quite likely mar the negative.

Photographic Lenses

Often cheaply obtainable, "symmetrical" forms of lenses will be found to be quite satisfactory for some kinds of work; the "Rapid Rectilinear" lens which was popular during the early years of this century is of this variety, and there must still be

a vast number to be found second-hand. This type of lens, under various names, is often fitted to low-priced folding cameras, but the focal length is too short to be useful. We shall require a lens which will give a picture bearing an obvious resemblance, in scale, to what we see when we look at the sky. A lens of 12 inches equivalent focal length will produce such a picture when held a foot from the eye (i.e. about ordinary reading distance). Friends can at last believe that what you have shown them is a picture of the sky corresponding to the area which would be covered by a "sixpence held at arms length." Finding such a lens means digging among the old stuff—when quarter-plates cost a penny each—or using more expensive modern lenses, perhaps of aircraft type. These are likely to be far more expensive, but some of them are superb. Lenses in this category were intended for many varied purposes. Like the war-surplus items for visual use, they are of high quality, but at the same time you must determine how closely the original purpose of the lens corresponds to your present needs; otherwise you may be disappointed. For meteor photography you need a fast lens with marginal definition only sufficiently high to enable position and magnitude of the meteor to be ascertained when it is, as sometimes happens, captured near the edge of the plate. If the central part of the plate provides high resolution and definition so much the better. Many lenses will do this. The very large Aero-Ektar, costing approximately £10 in the secondhand market, fairly expensive and fast disappearing nowadays, will cover a whole-plate when this standard is applied. It is fast enough when used with an "objective prism" to record spectra of meteors probably down to magnitude four—perhaps fainter—on fast material

like HPS. Other lenses by makers like Wray, Cooke, Ross, etc., will be found that produce high definition of stellar subjects, at least in the central part of the field. When this central portion of highest definition is small, use a very small plate and congratulate yourself on saving money.

For photographs of subjects like nebulae (in the absence of stray artificial light in the sky) use material that has a "high reciprocity failure." It will often be found fastest for the purpose, although, nominally the slowest when used for photographs at "snapshot" speed. Conversely, low reciprocity failure and "fast" material is likely to prove most useful for moderate length exposures (up to 20 minutes or thereabouts) when used on purely stellar types of object. This is not a treatise on photography and it is impossible to give more than a few hints to those who, having used their cameras for enjoyment on various other subjects, would now like to "have a go at the sky."

Guiding the Camera

The primitive, but rigidly made, box that forms the camera is attached to the telescope or its mounting, so that it will neither fall nor shake and slip about during exposure. A little trouble is necessary to ensure that the centre of the field of view of the camera bears some resemblance to the field of view of the telescope itself. Apply a reasonably high power eyepiece to the telescope and find a suitably bright star. Remember that a considerable amount of *evident* movement in the field of such an eyepiece will result in only a small change in the view obtained by the plate. Don't worry if you have to go to the edge of your eyepiece for a suitable star—bring it into the centre of the field and,

having some sort of graticule or pointer in the front focal-plane of the field lens, put the star well out of focus. This is your guide star. One method is to cut out a whole quadrant of the field of view with an opaque right-angled diaphragm in this focal plane. The grossly out-of-focus star—*well* out-of-focus remember—will take on the appearance of a large disc with a small black disc in the centre of it. This is caused by the shadow of the flat, from which radiate four black lines. Rotate the eyepiece so that the black quadrant of the opaque diaphragm falls neatly in one of the quadrants bounded by two of these dark lines. The corner will lie on the bullseye formed by the shadow of the flat on the mirror. When you are satisfied after a few minutes' practice, that you can keep the telescope rotating smoothly so that your pointer does not stray far from the black spot in the centre, you are all ready to go. Take off your hat (from the camera) and the exposure has commenced. Try not to hold your breath, and when you find the pointer straying, bring it back as smartly as possible. Try *not* to do this very gently and slowly and carefully; because all the time the pointer is away from the centre, light is being focussed on the plate just a little bit to one side, or above or below the position that marks where we should like our guide star to form its image, as pointlike as possible. Don't despair when it seems desperately hard. Just keep calm and remember your plate scale and your vastly magnified image of the star are two very different things. So long as you keep your pointer on the centre for most of the time and quickly get it back there when it strays, you will get a good picture.

CHAPTER X

Using the Telescope; General Principles

WE MUST soon draw to a close this brief introduction to some of the problems facing the amateur astronomer. It can be seen that many of these problems are not difficult to overcome if one is willing to accept the circumstances of his own case as something concerning which no one can know better than himself. It is possible for those with greater experience to give general advice and to quote the solutions that others have found in somewhat similar conditions.

In the long run, however, the observer must apply the experience of others to his own case with intelligence and discretion. It is possible that your adviser's astronomical interest is so completely different from yours that quite the wrong advice may be given without intention. Inevitably, practising observers are affected by their own line of study. Thus a really keen lunar observer, with his gaze on the surface of the moon, searching for the most minute clefts and craterlets with the aid of telescopes 10, 12, 15 and even 18 inches in aperture, is apt to consider a telescope very much smaller hardly a telescope at all. Again, the enthusiastic observer of variable stars will frequently be unaware of the existence of the planets except when one of them happens to come into the same field as one of his stars. He would seldom look at the Moon through his telescope for the very good reason that, especially during uncertain weather, time is limited enough for the job he is doing and enjoying,

without his eye being flooded with the intense light of the Moon.

A short re-consideration of some of the principles already stated in one form or another will help you arrive at a sensible solution. Remember how light is focussed by a lens and the effect of long-focus. Other forms of aberration than "chromatic" have not been dealt with but rest assured that they are there also; spherical aberration and off-axis astigmatism will, like chromatic aberration, be reduced—and definition improved—by the use of long-focus objectives.

Don't lightheartedly tear apart a well-designed prismatic instrument, just because "it was cheap," without knowing exactly what is involved in doing so. One of the things involved is some upsetting of the colour correction. If you are prepared to accept this in virtue of some compensating gain, and your purpose calls for it—well and good. But don't remove a short-focus glass from the company of its prismatic auxiliaries and then, having disposed of the almost certainly valuable low-power eyepiece that was part of the instrument in its original form, proceed to substitute a quarter inch or even more powerful, Huyghenian eyepiece and expect its original performance to be better in any respect save that of magnification. Modifications will almost certainly be far more successful, even if *not* perfect, if the original eyepiece is retained and the increased magnification obtained by use of a "negative" lens in the manner outlined in the section on the photographic use of the telescope.

Almost any sort of general advice, as must already be evident, is likely to become a list of "DON'TS." Keep the list in mind but DON'T make the mistake of assuming that it will be complete!

Enjoy using the telescope on the Sun. The Sun is for us a unique astronomical object; it is our nearest star and the only one which, with or without a telescope, has perceptible size. All other stars are so distant that even the 200 inch telescope still fails to show them as discs. But don't look at the Sun through the telescope directly, except perhaps in fog or with dark glasses, when it is very low in a particularly hazy evening sky, and can *easily* be stared at by the naked eye. *Remember that the telescope focusses invisible as well as visible light (and that it is the invisible infra-red rays that one is really using when lighting a piece of paper with a "burning-glass")*.

Even if the instrument of your choice is a small one—or perhaps binoculars—don't forget that your pleasure is likely to be increased if it is on some kind of mounting. A support of even a very simple kind will so improve the steadiness with which the telescope can be directed that far more stars will be revealed than would previously have been believed possible. Faint stars—too faint to be detected only because their light was spread by movement instead of being concentrated on the retina—will be seen where none was seen before.

Where anything but the smallest and lightest of telescopes is the choice, some sort of support will be necessary from the start even for casual stargazing, if much pleasure and profit is to be derived.

The various effects of increase in aperture on resolution and light grasp should be recalled, and, especially where fairly large instruments are concerned, the importance of steadiness in the mounting should be appreciated.

Do not overlook what was said concerning the manner in which an image is formed by a lens or mirror; that it is made up of a diffraction pattern whose exact form depends on the size of the aperture (and, incidently, on its shape) and the form of anything which intercepts the incoming beam of light. To this extent the image is an "illusion"; it passes well enough for all our likely puposes but the application of unreasonable magnification will soon expose it for what it really is. *You cannot magnify what is not present* and—whether due to insufficient size of objective, indifferent optical quality or bad seeing conditions—if the detail is not in the image it will not be seen by using a high-power microscope as an eyepiece! A good telescope will perform badly when conditions are really bad; the air above the telescope is part of the optical system that we can do nothing about. So give the telescope a proper chance. If it is a new one of no more than a couple of inches in diameter it is extremely unlikely that you will find out its full capabilities until you have used it many times. It is especially important to realise this if you have never before used a telescope seriously on the sky. If somebody tells you that a four-inch should easily separate the "Double-double" (Epsilon Lyræ), *if it's a decent one*, he is speaking the truth. If *your* four-inch—or even your six- or ten-inch—won't show you this fascinating quadruple star, it certainly does not mean you have been betrayed into embarking on the purchase of an expensive piece of rubbish! Be patient and see what the telescope does when, with the eyepiece well behind its usual position, the diffraction pattern of the star can be seen as a series of rings of light diminishing in brightness from centre to edge, and, apparently, almost stationary. Such an appear-

ance of the out-of-focus diffraction rings is not frequently met with in this country. Often they will be swirling furiously with tantalising changes of pace and odd will-o'-the-wisps of light chasing across them. When they are reasonably steady you will have a night of good seeing before you—perhaps really good. When they are stationary (and at this point we would expect more than one sardonic chuckle in the lecture hall) the seeing will be perfection. Do such conditions ever exist outside a laboratory with an “artificial” star? The answer is yes, or very nearly so. Surprising to the newcomer may be the information that conditions almost equivalent to this ideal are *sometimes experienced during light fog!* Unfortunately not all fogs produce such happy results, but it is a fact that seeing conditions for lunar and planetary observer are frequently far better than usual, and often *extremely* good, in conditions of light fog or fairly heavy haze. Other times most likely to produce stable air conditions and good seeing are around sunset and sunrise. Even on evenings when the latecomer finds bad conditions, the first hour after sunset—particularly on mild spring days—can be very fine. So perhaps the observer is not too badly treated after all. Regarding “seeing,” it will generally be least promising in the direction of a nearby house, owing to radiated heat from sun-warmed roofs, etc. Especially bad, in winter, will be the sky directly over, or to leeward of a chimney. A chimney sends up a column of warmed air, and *differences of refraction arise from differences of density in the transparent medium through which the light passes.* Air is more or less dense according to whether its temperature is low or high. Do remember this when considering whether to put your telescope on a permanent fixed mounting,

and find out if the corner of the garden which seems to offer the most sky is not the one which puts you in the worst possible position relative to your neighbour's chimney (with respect to the generally prevailing wind direction in your locality).

CHAPTER XI

Telescope Eyepieces

ALTHOUGH the principal function of the telescope eyepiece is to magnify the image formed by the objective, a simple "magnifying glass" is found to be unsuitable for any but the least critical purposes. The eyepiece is an optical instrument in itself, and can be thought of as a highly specialised form of microscope.

For best results the characteristics of the eyepiece must vary with the type of observation. The requirements are so varied—at times even conflicting—that no single eyepiece can be expected to satisfy them all. It is not possible, for example, to combine really high power with wide field of view, and even the attainment of a *relatively* wide field together with high power is apt to be an expensive business.

One thing above all stands out as important, particularly in the case of eyepieces intended for use with reflecting telescopes. The eyepiece should not introduce false colour to a perceptible degree; the reflector is essentially the *perfect achromatic instrument* and it would be complete folly to throw overboard this particular advantage by the use of an eyepiece noticeably weak in this respect.

In cases where the telescope is made to follow the apparent movement of the stars by some kind of hand control, the form of eyepiece should be such that the image does not deteriorate appreciably when the object under observation drifts from the centre of

the field of view; yet many eyepieces which are very deficient in this respect are in use by owners of very simple instruments. One must suppose either that the users are among the least critical of observers, or alternatively that the inconvenience that results is a matter of no particular moment to them.

Although, as we have already seen, it is necessary to magnify the telescope image, the beginner should beware of the lure of high power; not only is high magnification rarely necessary for most types of work, but the inevitable restriction of the real field of view that results is often a very severe disadvantage. A single example will suffice, it is hoped, to illustrate this. With a large telescope (say, greater than 12 inches in aperture) an eyepiece that would permit one to see the complete disc of the Moon would be a "wide-field" ocular, and represent a really low power; yet the passage of the Moon across the field of view, due to the Earth's rotation, would take no more than two minutes since the Moon covers approximately its own diameter ($\frac{1}{2}^\circ$) in this time. Now, suppose we apply an eyepiece giving a power of 500x; even if the field of such an eyepiece is *relatively* wide—as it might be if of an expensive form—this apparent field must be divided by the magnifying power, to get the *real* field. If the eyepiece has an apparent field of 40° , then the real field = 0.08° , or 4.8 minutes of arc.* If the telescope were not "following" the object, the planet, star or what-have-you would be seen positively to race from one side of the field of view to the other in a matter of less than half a minute, in about 20 seconds in fact. A pause of a couple of seconds, and the subject of observation would be well away from the centre of

*About $\frac{1}{2}$ the Moon's diameter

the field; in the case of a hand-guided telescope, particularly one which is not even blessed with sensitive slow-motion controls, but which has to be pushed around by direct hand pressure, the focussing of such an eyepiece properly would be a major operation and very much a hit or miss one at that.

It is unnecessary to suffer such inconvenience since it is almost certain that a well-focussed eyepiece of about half the power will show everything that the "five-hundred" is likely to show—and, in many cases, show it to better advantage; the image will be four times as bright, if it is a planet, and much more highly contrasted; the drift of the image in the field, arising from errors of guiding, will actually appear to be less than half. In addition, it is likely that the outer parts of the field will also be of a far higher quality than in the case of the more powerful system.

The appeal of low-power views of the sky has been mentioned earlier in this work and a word or two concerning really low-power eyepieces might not come amiss. Just as there is an upper limit to usable magnification so must there be a lower limit. The magnifying power of a complete telescope is derived from the ratio F/f ; where F = the focal length of the objective mirror or lens and f = the equivalent focal length of the eyepiece. When properly focussed, the eyepiece transmits in the form of "parallel beams" the light gathered by the objective, so that an eye (or camera), set for "infinity," is able to re-image the rays to form a picture on the retina (or photographic plate). With every telescope there is a position external to the system in which this bundle of

rays achieves a minimum diameter. This is the so-called eye-point, "back-focus," or Ramsden disc; this is the only proper position for the eye, and reference to this will be made when considering the various types of eyepiece. The size of this disc is equal to the diameter of the objective divided by the magnifying power—and its measurement is often used to determine the power of an "unknown" eyepiece. As an example, we shall take a three-inch telescope and a power of 20x; the "eyebeam" will be 0.15 in. in diameter; with a power of 10x the resulting eyebeam would be 0.3 in.—too large for the entire beam to enter the pupil of the eye even on the darkest night when the iris of the eye is fully dilated.

It is this, the relation between the iris opening and the size of the Ramsden disc which is the limiting factor in low-power magnification. Other considerations may arise which are peculiar to the individual observer; for example, if the eyepiece is of a form which affords scanty "eye-relief," it may be necessary for the observer who normally wears glasses to do without their assistance in order to place his eye in the correct position. If he has some degree of corneal astigmatism (an exceedingly common eye-defect) he is likely to do better with a somewhat higher power. The reason for this is that the area of the defective cornea affected will be less than when using the wider eye beam associated with low power. It is for this reason that even those with indifferent eyesight can see as well with very high powers as those whose sight is perfect. With the very small beams which extremely high powers involve, it would be a bad eye indeed that introduced noticeable errors when so "stopped-down." The unfortunate thing about an

excessively small eyebeam is that it emphasises the *internal* defects of the eye. Minute bits of "flotsam," fragments of opaque matter, dead corpuscles and so forth can be clearly seen by being sharply shadowed on the retina when the eyebeam is sufficiently small! A parallel example is the noticeable increase in the "spots and floaters" that one can see when feeling "liverish," on going out into bright sunshine, when the pupil suddenly contracts.

Eyepiece Types

So much for the general characteristics of low- and high-power oculars. But eyepieces are made in a variety of forms; some have very efficient-sounding foreign names, and some are called by the name of the person first devising or using them. Unfortunately this gives them a very respectable sound—especially when they are called after someone famous for astronomical work—and may lead the unwary to assume that his "named" eyepiece is one of unsurpassed excellence in just those respects in which it is, in reality, excessively weak! The diagrams showing the construction of the various more commonly used eyepieces are, it will be noticed, in a number of cases identified by the names of the originators in this way.

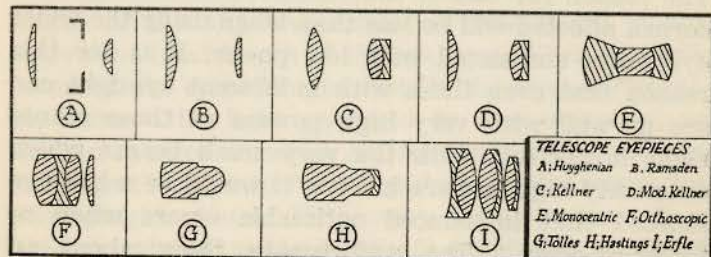

These diagrams are intended simply to show the arrangement of the various glass elements in the different types. It will be seen that some are very much more complex than others, and they range from the exceedingly simple to the modern Erfle eyepiece which comprises three separate achromatic pairs.

The Huyghenian Eyepiece

The **Huyghenian**—often misleadingly listed as a "standard" eyepiece, or sold simply as an "astronomical" eyepiece—represented a considerable advance over the one-lens ocular originally used by Kepler. Even so, it was designed for use with refractors of long focus and has no place in the outfit of the reflector user. It does not normally work well with instruments of relative apertures exceeding $f/12$ or $f/13$. The Huyghenian is what is often, misleadingly, called a negative eyepiece and, in practice, all the magnification is provided by the eye-lens. The field lens is positioned within the focus of the telescope and has the effect of greatly shortening the equivalent focal length of the objective and producing a new image in a plane within the interior of the eyepiece between its two lenses. This reduced-scale image is then powerfully magnified by the eye-lens which in the very high-power versions of this construction is a minute and steeply curved, almost hemispherical, piece of glass more like a watch-jewel than a lens. Needless to say, although it is a fairly simple type of eyepiece, the making of such a lens of quality—and its precise mounting—is not a cheap and easy process than can be carried out in a corner of the kitchen-workshop of the amateur mirror-maker. Small surface defects of the field lens, such as minor scratches and dust on the surface, are of no great

consequence as they are with some of the other forms.

Ramsden

A favourite with reflector users, largely because of cheapness, is the **Ramsden**. In its present-day form this should really be called a *modified Ramsden*; it comprises two plano-convex lenses with their curved surfaces towards each other and separated by a distance somewhat less than their common focal length. In its early form these two lenses were separated by a distance equal to their focal length and the resulting field of view was rather greater than in the form generally supplied. The disadvantage of the old arrangement lay in the fact that the "working distance" and the "eye relief" were both zero with respect to the glass surfaces to which they applied; hence every speck of dust and minor blemish on the front surface of the field lens was seen sharply focussed in the image plane of the telescope by the observer, while the full field of view was, in practice, unobtainable since it would have entailed coincidence of position as between the pupillary opening of the eye and the last surface of the eye-lens! Nevertheless, large eyepieces of this form have been found preferable to a number of other low-power eyepieces. Their main disadvantages arise from (a) slight off-axis astigmatism and (b) prismatic effects. Both are traceable to the wrong positioning of the eye, in the former case *along* the axis for the reasons mentioned above, and in the latter case to lateral displacement of the eye.

Kellner

In every way, except one, a great improvement on the Ramsden is the **Kellner** eyepiece. This is the most

commonly used type in binoculars and such instruments. Properly speaking, it comprises a "crossed convex" field lens and a cemented achromatic combination for an eye-lens. The effective field of view and the eye relief can be greater than in the Ramsden of similar equivalent focal-length. The form of Kellner eyepiece manufactured by Carl Zeiss, and much copied, makes use of a plano-convex field lens and an achromatic eye-lens. The principal disadvantage of the Kellner form is the tendency to form "ghost images" of bright objects lying off-axis, or even outside the field of view.

As would be expected, the use of more than one type of glass for both the field and eye-lens gives the designer a good deal more liberty (and the glass worker twice the number of surfaces to generate and polish); the achromatised Ramsden uses two such achromatic elements and, as a result, the field of view of the original form is more than regained, together with a very reasonable measure of eye relief.

For any further improvement in eyepieces, we are forced to make a choice as to how the improvement is to be brought about—and paid for. If we are prepared to sacrifice some of our wide field we can obtain a highly orthoscopic eyepiece without much trouble; if we want to retain the wide field and at the same time improve the orthoscopy so that it goes to the very edge of the field we shall want more money! Let us take the first choice first.

With suitable types of glass good orthoscopy can be achieved over a somewhat restricted field by making the eyepiece in the form of a cemented triplet; such is the "Steinheil Monocentric." An incidental advantage of this type of construction is that, since

there are no exposed, facing, glass surfaces light transmission is high and there is complete freedom from eyepiece "ghosts."

Orthoscopic

The **Zeiss-type Orthoscopic** eyepiece is somewhat similar in form, although the curves of the elements in the cemented triplet are no longer struck from a single centre. The addition of a weak eye-lens to compensate for the over-correction of the triplet that would otherwise be apparent, makes a considerably wider field available. This is a very fine type of eyepiece and well suited to reflecting telescopes of any focal-ratio normally encountered in amateur hands.

Tolles

Sometimes called the "poor man's orthoscopic," the **Tolles "solid" eyepiece** is, in effect, two lenses with external surfaces only! It is made from a single piece of glass, the curves at the ends representing two plano-convex lenses connected by a solid body of glass. Properly made, this lens yields fine definition, high light-transmission, coupled with as complete freedom from "ghosts" as the Monocentric. Since there are but two surfaces to work compared with the six of the Monocentric it can be made a good deal more cheaply. As might be expected, such virtues have to be paid for somehow, and in this case at the cost of limiting the effective field of view. In the Tolles eyepiece, this is rather restricted, and, power for power, will seem extremely so to those accustomed to more elaborate forms of eyepiece. It is, however, a valuable eyepiece to the planetary observer, giving a high contrast image. It can effectively be used with apertures as great as $f/8$ —but not much greater, without some

loss of image quality in the outer part of the field, which is already restricted to about 28° .

A moderate increase in field-width has been obtained with a modified form of eyepiece involving the cementing of a negative flint element to the eye end of the solid glass. This not only improves the colour in what would be the otherwise unusable parts of the field, but also enables some eye-relief to be obtained—a valuable gain, since this is at a minimum with the Tolles form.

Erfle

The only other type of eyepiece which it is proposed to consider is, strictly speaking, not an astronomical eyepiece at all. The **Erfle** military eyepiece is to be found in a number of instruments constructed on a price-no-object basis for war purposes—notably in the elbow telescopes of the 7x25 Bofors anti-aircraft predictor. It is fully orthoscopic over a very wide field. When this eyepiece is properly matched to the instrument, the field is as great as 65° , and even when a restrictive stop is fitted to compensate for any slight lack of balance, the field is still apt to be far greater than in other types. The colour correction is superb and the eye-relief reasonably generous: these qualities are obtained by using no less than six lenses in three separate achromatic pairs. It is unlikely to be manufactured specially for astronomical use, for sale to amateurs, since the production problems involved in the working of the twelve surfaces would make the price prohibitive, in view of the relatively small numbers that would need to be produced. However, since the value of the eyepiece is, in many cases, as great as that of the mirror or object glass with

which it is likely to be used, any chance to acquire one should not be missed.

The size of the capsule holding the lenses, in the form of instrument just mentioned, lends itself very readily to 1½ in. push-adaptors for astronomical instruments; or it can very easily be turned down along the greater part of its length, and the remaining portion threaded with a 55° form thread, 16 t.p.i., to fit standard R.A.S. drawtubes.

CHAPTER XII

Attachments and Auxiliaries

CERTAIN auxiliaries at the eyepiece end of the telescope deserve to be mentioned. These are the attachments which either erect the image for the purpose of adapting the telescope to terrestrial use, or deviate the image to permit observation of objects high in the sky without uncomfortable craning of the neck. In addition there are supplementary attachments for increasing or decreasing the effective focal length of the telescope and small eyepiece spectroscopes for the examination of stellar spectra.

Diagonals

The most common of all these attachments are the solar and stellar "diagonals." The former is a slip of glass, generally wedge-shaped, and having a truly plane, unsilvered, face presented to the Sun's rays focussed by the telescope. The greater part of the light and heat is refracted through the glass, while the smaller portion, which is to be used, is turned through an angle where it can be viewed as a "watered down" image in safety and comfort, with a moderately dense dark glass fitted over an ordinary eyepiece. The star-diagonal is simply a right-angled prism of sufficient size to take in the entire cone of rays presented to the eyepiece by the objective. One plane face is directed towards the object-glass; the other is uppermost, and below an adapter into which the eyepiece is inserted. The converging beam is totally deflected

through ninety degrees by internal reflection at the hypotenuse face of the prism, so permitting a "horizontal view of the zenith." Both types of prism pervert the image as well as diverting it. In other words the image viewed is a "mirror-image"; if used on terrestrial objects it would be seen that, although the top was uppermost, the left would be on the right and vice-versa. If an unsilvered pentagonal prism in a suitable mount were used for the solar, and a silvered prism of the same form for the stellar, diagonal, no reversal would take place; there would be an even number of reflections, and the image, although diverted, would be seen with exactly the same orientation that the telescope (whether astronomical or terrestrial) showed without it.

The Barlow Lens (see page 54)

The Barlow lens is simply a negative achromatic amplifier which works by intercepting the converging rays before they reach the focus, and, by refracting them "outwards" produces a new focal plane at a greater distance from the objective. The new focal plane represents a considerably greater increase of the effective, or *equivalent* focal length of the instrument than the actual position of the new focus would seem at first glance to indicate. The new, modified focal length is greater than the original *in the same ratio as the distance of the lens within the old focus is to its distance within the new focus*. Thus a Barlow lens which resulted in a focus being formed eight inches from itself when placed one inch inside the old focus would represent an increase in the effective focal length of the instrument of 800 per cent—together with increase of a similar order in the power of every eyepiece used in conjunction with it.

To be effective, a Barlow should be achromatic, made of properly matched glass, and of sufficient power to obtain a reasonable increase of magnification with moderate changes of position. If too weak, it will be necessary to place it a considerable distance inside the focus to obtain very much benefit—say a twofold amplification; if this distance is as much as five inches and the new focal plane 10 inches from the lens, an unwieldy length of drawtube will result.

CHAPTER XIII

Specialised Instruments

APART from the telescopes which the amateur is likely to use, and which have been mentioned already in this book, there are a number of others, some highly specialised, with which he should be familiar, since, even though he may never himself use them, much modern research is undertaken with their assistance, and he will constantly see reference to them in other works.

In some cases these instruments differ from the more normal types, principally in the manner in which they are mounted; in other cases the optical systems themselves are very different from that employed in the normal visual telescope, such as we commonly find in the possession of the amateur astronomer.

Specialised Types of Mounting

Various kinds of astronomical work make demands on the observer that could not be met if the telescope were mounted in the form of a straightforward equatorial instrument. Of fundamental importance in any observatory which has a "time department" is the transit instrument. This is a telescope which, as its name implies, is specially equipped to observe the transit of stars across the local meridian.

The Transit Telescope

The co-ordinates by which a star is catalogued and which give its position on the celestial sphere, are in

every way analagous to the terrestrial co-ordinates of longitude and latitude. It is essential to the navigator, for example, that the Right Ascension and Declination of the brighter stars be accurately known, and the ordinary telescope is not capable of determining with sufficient precision either one of these co-ordinates.

The Transit in a modern observatory invariably works in conjunction with a chronograph to record as nearly as possible the exact moment at which a given star crosses the local meridian. Where the star's Right Ascension is already known, this will yield very accurately the Local Time, since the Right Ascension of any star is simply the Local Sidereal Time of all points lying on the meridian, or line of Longitude, over which it passes at any given moment. Formerly, it was usual to have the chronograph associated with the telescope marked by the observer pressing a key, at the moment, as nearly as he could judge it accurately, when the star actually crossed the fine web running from the N. to S. points in the field of his eyepiece. The normal procedure was for the observer to give a "rattle" on the key at the approach of the star, and this served to make the relevant signal easy to find on the chronograph, when the paper was taken from the chronograph drum. Usually a series of wires or webs preceded the actual meridian web, and the successive transit of these gave the observer some chance to "get the feel" of the star's motion, as it were, before the critical instant.

Nevertheless, as there was of course a considerable variety among observers, it was necessary to take into account the "personal equation" of the individual observer. The human eye and the human mind do not,

it seems, provide a combination which makes for the accurate recording of instantaneous phenomena; where one person *anticipates* by a fraction of a second, another will record the event a little late, and for this reason it becomes necessary to know just who recorded the transit in order to apply the required correction. Once the observer's personal equation is established, it is seen to be fairly constant and good results are to be had despite the initial error. A more usual form of instrument nowadays incorporates a moving wire actuated by an accurate micrometer screw under the observer's control, by means of which the star's image is kept constantly bisected during its passage across the field of view, and the moment of actual transit is recorded automatically. Optically, the telescope is quite unremarkable. It is in the form of mounting that the instrument departs from the usual. In the first place the telescope is moveable in only a single plane on a horizontal axis. Elaborate precautions are taken to ensure that no sensible deviation of this axis, once established, is likely to arise, and the whole structure is extremely formidable when looked at in relation to the actual size of the telescope itself, which is no more than a few inches in aperture. The tube is remarkably robust by ordinary standards, while the piers on which the axle is borne are of a specially solid nature. The object glass is collimated with special care to ensure that the optical axis represents the true meridian. Obviously such a telescope as this can do one job only, and it is designed to do it particularly well.

A good many amateurs have made use of transit instruments—some even making their own—by which means they have been able to provide their own accurate time checks. When such a telescope is contem-

plated it should be borne in mind that the same principles of rigidity outlined above must apply if the instrument is to be of any practical use. The telescope can be quite small although magnification should be reasonably high if any great accuracy is to be attained. The axis should be as robust as possible and the telescope tube free from any trace of flexure. One of the large and heavy gunsight telescopes with the erector removed and the object glass replaced by one of greater focal length would serve better, probably, than the more usual amateur's brass-tube refractor. Two-inch diameter bearings would not be too robust for a telescope applied to this type of work.

The Meridian Circle

The Meridian Circle is a kind of cousin to the Transit. Like the former, its rotation is confined to a single plane but its job is to record not the time but the *altitude* of a star in transit. A large divided circle of extreme accuracy is integrated with the axis, and the altitude of any star whose image is bisected by the horizontal wire in the focal plane at the moment of transit can be read off by means of microscopes attached to the very accurately divided circle. Such a circle has a degree of accuracy which would make an ordinary protractor seem a crude instrument indeed; nevertheless corrections other than those required by the differential refraction of the atmosphere normally have to be applied if the most accurate determination of a star's declination is to be made.

Modifications to Standard Type Instruments

When the star under observation is at a high altitude there may be great physical strain imposed

on the observer. It may therefore be advisable to modify the design of the telescope, so as to allow the observer to work in greater comfort. More accurate readings are likely to result when the observer is comfortable; it was often the practice to have him in a reclining position on a bed-like contraption, propped between the piers of a transit telescope, when making observations of high-altitude stars. A form of instrument which makes this elaborate preparation unnecessary is the so-called *broken-transit*. In this type of telescope, the light being focussed by the object glass is given a 90° deviation, by means of an accurate prism, so bringing the eyepiece to a more comfortable observing position in much the same manner as was adopted in the elbow-type predictor telescopes described in the section on war-surplus instruments.

Coudé Type Telescopes

We have already seen that the Earth's rotation imposes problems on the designer of instruments intended for astronomical observations; the fundamental one where prolonged observations of any single object are concerned, is that of making the telescope "follow" the object with as great an accuracy and as little complication as possible. Even when the means have been provided as far as the instrument itself is concerned, there remain residual problems in some kinds of work. In the Fraunhofer or German-type equatorial, for example, it is not possible, without modifying the instrument in some way, to follow a star of similar declination to the observer's geographical latitude, from very far East of the local meridian to very far West of it, without reversing the telescope

(turning it through 180° in declination) and bringing it to the opposite side of the pier or tripod on which the equatorial is mounted (rotating it through 12h of Right Ascension). Various means have been adopted to circumvent this, both in refractors and in reflector-type instruments. With a refractor it is possible, if the instrument is of short focus, to divert the converging beam so that it passes through a hollow declination axis in much the same manner as in the broken-transit mentioned earlier.

Fixed Eyepiece-Position Types

The fact that a total-reflection prism or reflecting plane mirror in the optical train can be used to bring the rays to a focus at a more convenient point has been exploited many times and in a variety of ways. Some of the methods used seem to have considerable appeal among amateur telescope makers in the United States, while others have been employed both in temporary and in permanent form by professional workers at observatories in many countries.

To the amateur, the notion of a fixed eyepiece position makes its appeal largely because of the physical convenience enjoyed by the observer. In some instances, advantage has been taken of the possibility it offers of having the observer seated in a comfortable indoor position while the telescope remains outside! In one well-known form to be described (the Porter-Springfield mounting) the light from the objective mirror is brought to a focus in such a way that the observer can have a fixed seat, while viewing the sky, by looking in a downward direction through an eyepiece in the polar axis of the telescope.

Among professional instruments the Equatorial Coudé of the Paris Observatory and the Sheepshanks telescope at Cambridge, and at least one telescope of Harvard Observatory, have been so arranged that the observer is seated indoors. Among more temporary arrangements, the Pickering-Harvard expedition to Jamaica at the beginning of the century made use of a fixed telescope of extremely long focus to prepare the Harvard Photographic Atlas of the Moon. Eclipse expeditions commonly use a somewhat similar arrangement for producing spectrographic records at the times of total eclipse, while the daily work at solar-physics laboratories and observatories throughout the world would hardly be possible without some arrangement for a fixed observing position. For the purpose of this brief survey, we can divide all these instruments into two main classes, although they might well be divided in almost any other fashion. In every case it is necessary to make use of a system of reflection, even when the telescope is really a refracting system. Our division, made for convenience only, is one for separating those in which the light undergoes reflection *before* being submitted to convergence by the optical system from those in which the principal optical surfaces have already done their work before the subsidiary reflection, which brings the focussed light where it is required.

Solar Telescopes

Solar instruments almost invariably make use of an external reflecting system to bring the light to the objective of a fixed instrument. The reason is simple: the light provided by the Sun is ample for detailed spectroscopic examination and for large-

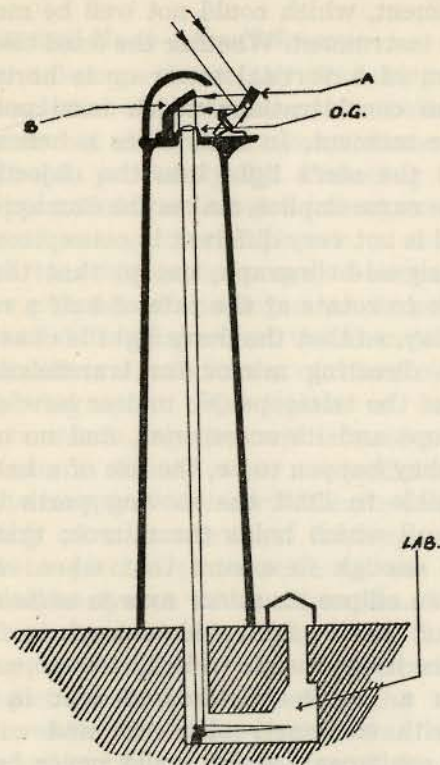

TOWER-TELESCOPE: THE SUN'S LIGHT IS CONSTANTLY DIRECTED VIA THE HELIOSTAT (A) AND DIRECTING MIRROR (B) INTO THE OBJECT-GLASS (O.G.). THE IMAGE IS FOCUSED BELOW GROUND VIA THE FLAT AT THE BOTTOM OF THE SHAFT. THE HELIOSTAT IS EQUATORIALLY MOUNTED AND IS DRIVEN AT RATE OF $\frac{1}{2}$ rev p. day.

scale photography. Such work calls not only for instruments of long focus, but also for elaborate and weighty equipment, which could not well be mounted on a moveable instrument. Whether the fixed telescope takes the form of a vertical tower or is horizontal, will depend on considerations which need not concern us at the moment. In both cases a heliostat is used to direct the sun's light into the objective. A heliostat, as its name implies, makes the Sun appear to stand still, and is not very different in conception from the ordinary signal-heliograph, except that the first mirror is made to rotate at the rate of half a revolution per civil day, so that the Sun's light is constantly passed to the directing mirror for transmission to the objective of the telescope. No matter how elaborate the telescope and its accessories, and no matter how weighty they happen to be, the use of a heliostat makes it possible to limit the moving parts to the fairly simple cell which holds the mirror; this need be only large enough to ensure that when seen in projection as an ellipse its minor axis is sufficient to offer a beam of parallel light wide enough to fill the objective. Hence it is possible to build telescopes with object glasses a couple of hundred feet in focal length, and with extremely elaborate and complex spectrographic equipment, which could never be contemplated if it had to be fixed to a moving telescope. Modern precise spectrographic work demands a laboratory with stable temperature conditions and extremely solid and stable mountings for the varied apparatus of which it makes use. The tower telescope enables the Sun's light to be brought into an underground laboratory, where the ideal conditions are to be found, and where work of the most precise nature can be carried out without the fluctuations of tempera-

ture brought about above ground by the radiation of the object for whose study it is designed.

The Harvard Moon-Atlas Telescope

The telescope taken by Pickering to Jamaica, mentioned earlier, made use of the heliostat principle for somewhat different reasons. Since Jamaica had been found previously by Pickering (who was a keen student of the Lunar surface) to offer remarkably good seeing to the planetary observer, it was decided to erect a temporary observatory for the express purpose of making a whole series of photographs of different parts of the Moon's surface under several different conditions of illumination. A nine-inch photographic object glass of extremely long focus was made, together with a twelve-inch diameter plane mirror. Funds were not sufficient to build a tower telescope of the sort described above, and the mounting of a conventional telescope of the length needed to give a plate scale of the required size was completely out of the question. The "telescope tube" was made in the form of a tunnel-like shed running up a hillside. The twelve-inch mirror and the object glass were placed at the bottom of the tunnel, while the plate-holder was situated in a small shed at the top. By means of the mirror, which had a clear view from horizon to horizon in an East-West direction, the Moon could be observed or photographed at any time when it was in the sky.

Unfortunately, the photographs which resulted—although of considerable interest, and on a larger scale than any previously obtained—were nothing like so good as had been hoped, since the twelve-inch flat mirror turned out to have a faulty figure. This lack of quality necessitated masking off the outer

portion with the result that the nine-inch lens which had been made at considerable expense was working with an effective aperture not of nine but of six inches.

Amateur Instruments Based on Pickering's Model

From time to time variants of this type of telescope have been made, sometimes by amateurs. There seems to be some fundamental appeal in extra long-focus instruments, and, where refractors are concerned, there is no doubt that certain advantages are obtained, where the light is abundant, by making the object glass of great focal length in relation to its aperture. This was illustrated by the example of the non-achromatic object glass discussed in the early pages of this book. In the case of the achromatic object glasses something of the same can be said. Since object glasses are normally corrected to give identical focus for *incident parallel light of only two specific wavelengths in the entire visible spectrum* it stands to reason that even the achromatic objective must transmit a certain amount of light, outside and between these two wavelengths, which is not perfectly focussed in the chosen image plane; this accounts for the "secondary spectrum." If the ratio of focal length to aperture is sufficiently high the secondary spectrum, although still existing, will be less noticeable.

Where reflecting instruments are concerned, the only real advantage of great focal length lies in the increased image scale which results. It has already been pointed out in the section dealing with the use of the Newtonian Reflector as a camera, that scale can be increased by suitable modification of the instrument, using a special lens in the optical system, to give rise to an increase in the *equivalent* focal length of the combination without increasing greatly

the length of the instrument itself. It is entirely possible to produce the same effect making use only of reflecting surfaces. The two principal types of telescope embodying this principle are by no means new; both the Gregorian and the Cassegrain telescope were conceived more than 200 years ago, although it is only in more recent times that they have been made with the qualities demanded for serious astronomical study.

The Gregorian Telescope

The Gregorian, which takes its name from James Gregory, a brilliant Scottish investigator of optical theory, was at one time extremely popular in very small sizes suitable for the pocket. Giving an erect image, it could be used as a terrestrial spyglass at a time when the quality of object glass left much to be desired. The basis of the instrument is simplicity itself. Just as light emanating from a point at the centre of curvature of a spherically curved surface will be reflected back to the centre without aberration, so will light emanating from the "principal focus" of an elliptically curved surface be reflected without aberration to its *second focus*. We have already seen that a properly figured paraboloidal mirror is capable of forming an aberration-free image of an axial star at its own focus, and it seemed clear to Gregory that if two mirrors, one a small ellipsoid and the other a large paraboloid, were so opposed that the focus of the paraboloid and the principal focus of the ellipsoid were exactly coincident, a second reflection would result in the formation of a new image at the empty focus of the smaller of the two mirrors. This is illustrated diagrammatically on page 48. The resulting

amplification of the image is measured by the ratio of the distances: vertex of the ellipsoid/principal focus and vertex/second focus. Since the final image, to be accessible, must be external to the optical system, it is necessary to provide a central perforation in the larger of the two mirrors through which the light can pass to the second focus. Thus the telescope is used by the observer in the same way as a refractor, with the telescope eyepiece at the bottom end of the tube.

The Cassegrain

This is the common form of observatory reflector, and is somewhat analogous to the Gregorian, although, since it provides an inverted image, its characteristics in use are similar to the modified Newtonian-Barlow combination. In the case of the Cassegrain the smaller mirror takes the form of a convex-hyperboloid, and is placed *within*, instead of beyond, the focus of the primary mirror. Again it is necessary to provide a central hole in the main mirror by which the light can reach the ultimate focus, or, alternatively, to provide yet a third mirror in the form of an inclined plane to bring the focus to the side of the tube as in a Newtonian instrument

In both of the foregoing types of instrument it is usual to provide more than one secondary mirror of alternative focal length and by this means the effective focal length of the entire combination can be altered at will. In the case of the Cassegrain it is usual, in observatory instruments, to provide at least one hyperboloid of very great power, which, when used, results in the focus being brought right outside the instrument. Where very large telescopes are con-

cerned, it is possible to employ a third reflecting surface intermediate between the two mirrors, which can be made to rotate at half the rate of the telescope itself, so that the focus can be brought to a fixed position in a spectrographic room. This is a variant of the Coudé form of telescope and the focal-length resulting can be very great indeed—in the case of the 200 inch telescope it is no less than 500 feet.

At one time the Gregorian and, later the Cassegrain, seem to have exercised an almost fatal fascination for the amateur optical worker. It can be seen from the diagrams that the Cassegrain in particular provides in compact form a telescope which is the optical equivalent of a telescope several times its own length. For the amateur there are certain snags, not least of which is the difficulty of figuring the small mirror to a satisfactory degree of accuracy. The concave ellipsoid of the Gregorian can try the patience of the amateur who has previously only attempted paraboloids; the convex mirror used with the Cassegrain offers even greater problems. The best way is first to figure and silver the primary and then to figure the secondary by repeated trial in the telescope. Such a course may be reasonably certain if one is blessed with plenty of time as well as infinite patience, but by no stretch of imagination can the process be described as swift. Even when the job is done, and done successfully, opinions are apt to vary as to whether it is worth while. One authority with a great deal of experience of many kinds of instrument holds firmly to the view that the Cassegrain "combines in the highest possible degree all the disadvantages of both the refractor and the reflector!"

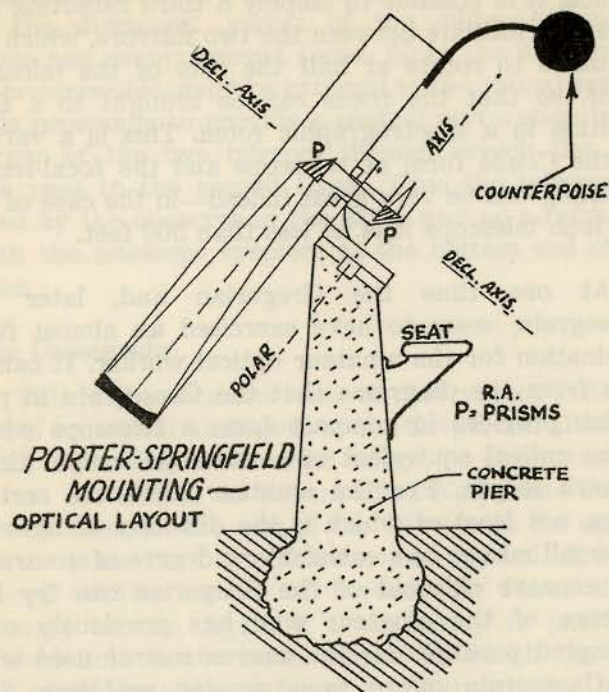

The "Springfield" Mounting

Before leaving altogether the older forms of reflecting telescope, some mention should be made of the Porter-Springfield mounting. This was designed to provide the user of the Newtonian telescope with a fixed and comfortable observing position. It has proved extremely popular among amateur telescope makers in the United States, although no record of its use for serious amateur observational work seems to be available. Mechanically, this form of telescope is ingenious; the telescope is mounted to one side of the polar axis which is in the form of a

stub, and the normal Newtonian flat or prism is placed so that it reflects the light down a hollow declination axis. Another prism, placed at the point where the projected axes would intersect, turns the converging beam through 90 degrees, so that the final portion lies directly above and parallel with the polar axis.

The observer is able to look *down* through the eyepiece (more or less steeply according to the latitude of his observatory). There can certainly be no gainsaying the physical advantages of such an arrangement. Unfortunately, the fact that so much has been made of this point has been known to deter those, who were unable to undertake something so complicated, by giving the impression that the conventional Newtonian must be an awkward and uncomfortable instrument to use. This most certainly is not the case; it is a most convenient telescope to operate. The Springfield will appeal mostly to those who have not had any very great experience of the Newtonian—or to those who are keener on making telescopes than using them. The great virtue of the Newtonian is its optical simplicity—just a paraboloid, a plane optical surface, and a magnifying eyepiece. For highest performance *the use of a prism in place of a flat should be discouraged*, since three optical surfaces instead of one are involved, and any errors are cumulative; yet quite frequently Springfield designs show the second and third reflections both being obtained by prisms—*six* surfaces against the one of the standard Newtonian! In addition, the first flat or prism in the Springfield must be far larger than in the usual form of telescope if full illumination of the field is to be obtained, since it has to be placed considerably further down the cone of rays from the main mirror, in order to bring the focus not only outside the

tube but round a second corner also. Furthermore, some of the alleged advantages are apt to be outweighed when any serious observations are undertaken.

For example, the reflection from the second prism results in a mirror-reversed image being obtained, making identification of star fields from ordinary charts unnecessarily complicated and providing "left-handed" views of the Moon and planets. In addition, the orientation of objects in the field of view is constantly changing, as the telescope is rotated so that North is sometimes at the top, sometimes at the bottom, and at other times on the right or left of the eyepiece, and one of the principal advantages of the ordinary form of equatorial instrument is thus thrown overboard. With the normal Newtonian the eyepiece is usually set exactly at the side of the tube, so that the E-W line runs parallel with the tube itself in the eyepiece, and the orientation of objects in the field of view is easily recognised, no matter in which direction they happen to lie in relation to the ground on which the telescope stands. All this, plus the fact that the making of a mounting of the Springfield pattern can hardly be undertaken without formidable machining equipment probably accounts for its not having gained any popularity among those who require a home-made telescope for more or less earnest study.

CHAPTER XIV

Catadioptric Systems

THE SIMPLEST of all optical surfaces to produce are those which are spherical in form, but unhappily it is a matter of hard geometric reality that parallel rays reflected from (or refracted through) a spherical surface do not meet at an accurate point. This is due to spherical aberration. Moreover, the deeper the curve the more pronounced is this effect. Hence the need to "figure" lenses and mirrors intended for use in astronomy, to eliminate or reduce the spherical aberration.

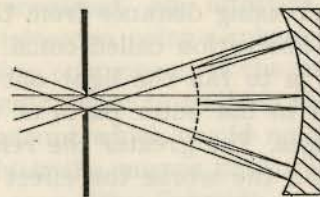

Spherical Mirror + Small Stop at Centre of Curvature; Wide-field, coma-free, curved focal surface—low photographic-speed.

Nevertheless it has long been realised that a mirror, consisting of a sufficiently small portion of a spherical surface, has a negligible amount of spherical aberration. A large diaphragm with a small opening in the centre, when placed near the centre of curvature of a large and deep spherically curved mirror, has the optical effect (see diagram) of turning the large

mirror into an infinite series of small ones. Such a system is capable of forming good images over a wide field on a focal surface which is curved concentric with that of the mirror. These facts, long known, but not hitherto utilised, ultimately led to one of the greatest strides in the field of practical optics since the invention of the telescope. The spherical mirror stopped down at the centre of curvature would not only be impossibly slow, but incapable of practical utilisation—yet its legitimate descendants form a group of the fastest photographic instruments ever devised.

There have been many attempts to make the ordinary short focus paraboloid suitable for the photography of moderate-sized fields; by itself the paraboloid is unsatisfactory for this application. The reason is that, although it produced excellent definition *on the optical axis*, definition falls off quite rapidly with increasing distance from the axis, owing to an intrinsic aberration called coma. The effect of this aberration is to fan the light out so that point sources of light in the outer parts of the field form fan-shaped images. The greater the relative aperture of the paraboloid the worse the effect becomes, and it is a usual practice with large reflectors of fairly short focus to incorporate a correcting-lens at some point, to enable a larger field of view to be photographed than would otherwise be possible. Without the use of such correctors, the effective angular field of the 200 inch reflector, when working at the prime focus, would be only *a few minutes of arc*.

The Schmidt Telescope

A spherical mirror, on the other hand, is not subject to coma, but only to spherical aberration, and

it is clear that, if the rays can be brought to a focus by some means other than figuring the surface to a paraboloid (which immediately introduces coma), then the useful field of view could be very much increased. The difference between the work of Bernard Schmidt and the previous attempts which had been made to overcome this problem, is really one of approach. Nearly always the methods used had involved the correction of the converging cone of rays coming *from* the mirror. Schmidt's reasoning must have been very straightforward: a spherical mirror was able to form a perfect image of a point placed at its centre of curvature; and a large spherical mirror behaved perfectly well optically when a stop placed near its centre of curvature had the effect of making all objects cast their light on to a *section* of the mirror; each section then acted as a sensibly aberration-free reflector. Schmidt argued that it should be possible to construct an effective large-aperture photographic telescope, using a spherical optical mirror as the focussing component, if the incident rays had their path altered, *prior to striking the reflecting surface*, by an amount which would nullify the spherical aberration which the mirror produced, when dealing with parallel rays. The Schmidt "correcting plate," which is a thin lens of special form, provides each incident ray with a new path—the amount of deviation depending upon which part of the mirror surface it is intended to strike—so that all the rays from any infinitely distant point source (star) come to a true focus after reflection. There are many forms which a Schmidt plate can take; none of them is simple and all are a good deal more difficult to figure than any "normal" optical surface. Since the plate is placed very near to the centre of curvature a Schmidt tele-

scope has to be approximately twice as long as the focal length of the mirror. The focal surface is curved and the photographic plate or film has to be sprung to the required curve against a properly formed seating in the plate-holder. The photographic speed can be extremely high; $f/1.5$ is a fairly common speed for a Schmidt and, with modified forms, relative apertures of $f/0.35$ are possible.

The Maksutov Telescope

Dmitri Maksutov filed claim for a patent in Russia in November 1941 for an entirely new form of telescope. This, too, is a *catadioptric system*, i.e. one using a combination of refracting and reflecting surfaces.

The beauty of Maksutov's conception lies in its simplicity and compactness. Where Schmidt placed the correcting plate near to the centre of curvature of the mirror, so lengthening the instrument, the Maksutov has a correcting lens placed very near to the focus. In large instruments this is of great importance and can result in the saving of thousands of pounds on each instrument set up for observatory use, owing to the smaller size of dome required to house it.

The simplicity of the Maksutov lies in the shape of the optical surfaces. Where the Schmidt necessitates a correcting plate of complex form which still has to be figured largely by trial and error, the Maksutov uses nothing but spherical surfaces. The corrector in the Maksutov turns to advantage the inherent fault of the meniscus lens. Spherical aberration in a meniscus lens, using reasonably deep curves, is gross; for this reason it is often used as a single component in camera lenses of complex form to smooth out spherical aberration of opposite sign resulting from the other elements in a combination. The Maksutov corrector is a deep

meniscus having very little power but considerable spherical aberration. Since the spherical aberration is a function of the degree of "bending" in the lens design rather than in its actual power, it can be seen that the designer of a Maksutov instrument is well provided with the means of correcting for errors which in the Schmidt form would involve a correcting plate of very special figure, and possibly needing a compound corrector to avoid false colour effects. The chromatic aberration in any normal Maksutov is negligible—even when the most precise kind of work is intended.

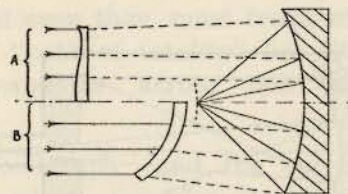

CATADIOPTRIC SYSTEMS; Schmidt (A), Maksutov (B).
 (A) with aspheric "correcting plate" at Centre of Curvature
 (B) with Meniscus Correcting Lens near focus. Both
 Systems are Wide-field, coma-free and of very high
 photographic speed, focal surface is curved

The meniscus (see diagram) is extremely deep, calling for very thick blanks; consequently, since the glass must be of exceptional quality, it is expensive.

Like the Schmidt, the Maksutov offers the designer a good deal of scope, and many varieties are possible. In the normal astronomical instrument the correcting lens has its curves convex to the mirror. By suitable modification of the corrector it can be placed within the focus of the mirror, and, with a small central mirror attached to the inner surface of the meniscus a Maksutov/Cassegrain results. With the corrector

concave to the objective mirror, and placed beyond the focus, a small central portion of the lens can be silvered, resulting in an erect-image system superior in every way to the old Gregorian. Such an instrument is not only compact, but its effective focal length is such that wide-angle eyepieces can be used, while still having considerable total magnification in the instrument as a whole. Anyone who has used one of these instruments must have been struck by the clarity and crispness of the image, while its apparent total absence of false colour right to the very edge of the field of view makes it a joy to use for terrestrial subjects.

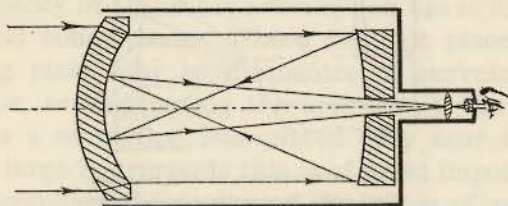

Maksutov-Gregorian Telescope

It is perhaps unfortunate that the Maksutov should have appeared on the scene just as many workers in different parts of the world had mastered the intricate art of figuring Schmidt correcting plates. Europe generally, and America also, was already Schmidt-conscious and many Schmidt construction projects were already under way. In Russia, however, it was a different story. The destruction of equipment at Pulkhovo and other observatories in the Ukraine and in the Crimea, and the post-war extension of astronomical work at many observatories throughout the whole country have led to something like the whole-

sale construction of Maksutov telescopes in the Soviet Union, many of them of great size.

The Lyot Coronagraph

Although the Sun is the nearest star and its light is so abundant, its full investigation calls for study of the corona, as well as the photosphere and prominences; the light from the corona although always present, is normally invisible because of the scattering of photospheric light in the Earth's atmosphere. At times of total eclipse, when the photosphere is hidden by the body of the Moon it becomes observable. Unfortunately, good total eclipses are rare and even then, most frequently, the greater part of the "path of totality" lies either across the world's oceans or across not easily accessible territory.

The coronagraph (and the coronoscope) is an instrument which provides its own total eclipse, making it possible to study the changing form of the solar corona without the assistance of the Moon. The principle is extremely simple; the Sun's light is focussed in the usual way by an object glass, but the interposition of a small occulting device masks the image of the actual body of the Sun; in addition a small reflector has to be placed so as to reflect the heat and light out of the tube. What remains outside the occulting disc is the portion of the sky immediately surrounding the Sun. It is necessary to re-image this via a collimator and viewing telescope before the corona can be seen.

Although the conception is simple, in practice the making of a good coronagraph is far from easy. The optical quality of the object glass must be

especially high, and the polish without blemish of any kind; a few minute imperfections or scratches would be sufficient to scatter enough light to make photography of the faint light of the corona impossible. Rigid control of working conditions during the making of all the lenses involved is absolutely essential and even when the instrument is completed the contrast available is not nearly as high as that obtained during a natural eclipse. The first coronagraph, when used in Paris, although it showed prominences, failed to reveal the Corona. The atmosphere near large cities is simply not clear or clean enough. To be effective the instrument needs a high altitude observatory, and it is at such locations as the High Altitude Station in Colorado, and the Pic du Midi, high in the Pyrenees, that the coronagraph does its most valuable work. It is unlikely that many amateurs will ever have the chance to see a coronagraph, let alone use one; any amateur observing-programme connected with the Sun is likely to be concerned, in any case, with less profound studies than that of the corona.

The Spectrohelioscope

Observation of sunspots and solar prominences has been a favourite occupation with amateur astronomers ever since the invention of the spectroscope. Attention has already been drawn to the dangers inherent in direct observation of the Sun through the telescope. However, the projection method of viewing previously outlined, although it is well able to reveal the detailed structure of sunspots etc., is not suited for the observation of prominences.

There are several ways in which these can be observed and all involve the isolating, in some way,

of a narrow region of the solar spectrum. It is possible, for example, to construct a monochromatic filter with alternate layers of quartz and polaroid, but such a method is neither easy nor cheap; nor will it be effective in operation except under conditions of strict temperature control.

By far the easiest method of observing prominences is via the solar spectroscope. The image is focussed on the spectroscope slit, and, after collimation and dispersion by the prism-train or grating, a suitable line (generally the $H\alpha$, in the red) is chosen, and the viewing telescope is trained on it. If the slit is so placed that it lies tangent to the edge of the Sun and is carefully made to travel the Sun's circumference, any activity, flares and so forth, will be apparent. $H\alpha$ is a dark line in the solar spectrum and one of the widest; it is a hydrogen line, and anything seen to happen in " $H\alpha$ -light" is, in fact, happening to hydrogen above the solar surface. It is quite easy to open the slit to a considerable width once something of interest has been located, and, so long as it is not wide enough to take in light from beyond the limits of the dark line, the opened slit forms a sort of narrow window through which a portion of the Sun's surface can be seen in monochromatic light.

If the entire surface is to be seen at once, the spectrohelioscope provides the answer. Again, this is a somewhat costly instrument for amateur construction. A heliostat is required, and also a *good* non-achromatic object glass. The latter is of great focal length and projects the solar image into a darkened room. The spectrum (of considerable dispersion) is obtained via a diffraction grating, and rapid scanning of the entire solar disc in light of a single colour

(again, the $H\alpha$ line of Hydrogen is generally chosen because of its width) is made possible by a system of rotating square prisms or, alternatively, by a vibrating scanning-slit. Although the Sun is actually seen intermittently by the observer, the rate of scan is such that persistence of vision provides the illusion of continuity, in precisely the same way as it does when viewing a film or television picture.

Almost all the instruments mentioned in this section have at one time or another been made and used by amateurs; nevertheless, they can hardly be regarded as normal equipment for the amateur astronomer, and the brief details set out here are an insufficient guide to anyone wishing to construct one of them. Optical work, especially for the beginner, has many hidden snags; some of them can be overcome by persistent trying; but it should be remembered that the more complex the optical system, the more involved the mechanical work is likely to be, and, for the person who is primarily interested in observing, the time-tested and highly efficient Newtonian telescope, or standard refractor, is likely to prove of greater benefit than any other.

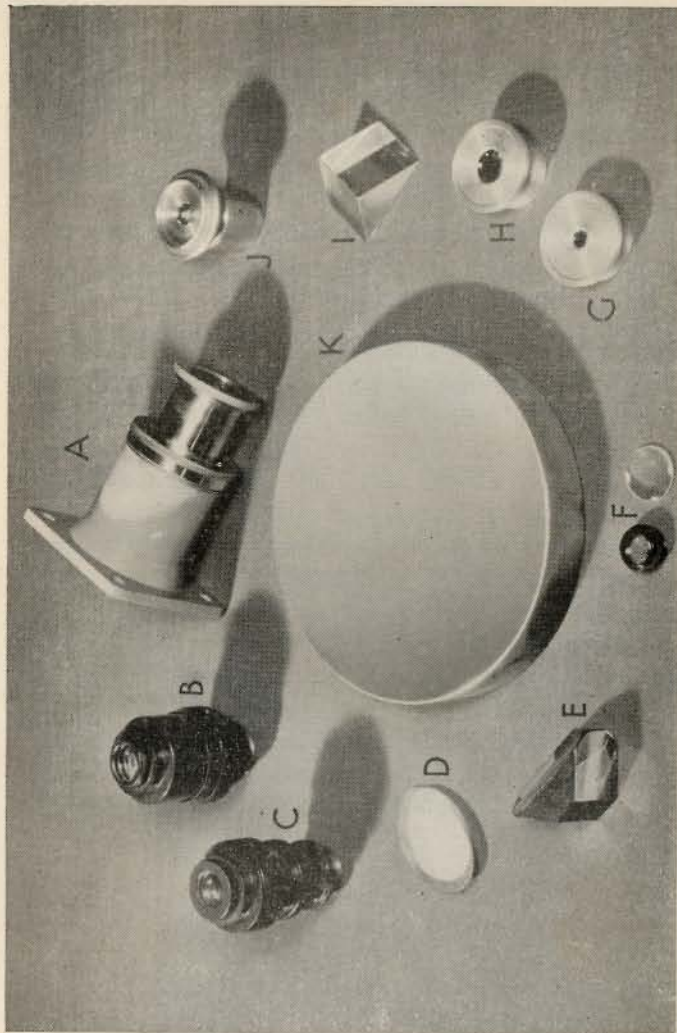

Typical equipment used in the construction of a Newtonian Reflector:—

- (A) Focussing mount taking standard R.A.S. eyepieces.
- (B) Kellner eyepiece, $1\frac{1}{2}$ " focal length.
- (C) Orthoscopic eyepiece, $\frac{5}{8}$ " focal length.
- (D) Aluminised elliptical plane mirror.
- (E) Roof Prism. When used in place of an elliptical flat an erect image is obtained.
- (F) Achromatic eye lens and plano-convex field lens for Kellner eyepiece.
- (G) & (H) Ramsden eyepieces.
- (I) Right angle prism—can be used in place of the elliptical plane-mirror.
- (U) A remounted eyepiece of the six-element Erfle type.
- (K) Six-inch paraboloidal mirror.

CHAPTER XV

Making a Reflecting Telescope —and Mounting It

WHETHER the amateur is purchasing or making his own telescope mirror, it is impossible to place too much emphasis on the fact that the mirror itself represents *only a part of the telescope*. It is necessary to mount the mirror, eyepiece—and the intermediate flat or prism—in such a way that the optical components can be brought into proper relationship, in order to ensure that the telescope shall perform as a high quality optical instrument.

A glance at the diagram showing, schematically, the layout of a Newtonian telescope, will make clear the requirements. What the diagram cannot make clear is the *degree* of accuracy that must be achieved if the care that has gone into the figuring of the optical surfaces is to reward the owner with the definition and resolution of which they are theoretically capable. The paraboloid is extremely sensitive to slight misalignments, and it is essential that the eyepiece be properly positioned on, and along, the optical axis. It can be seen that if the optical axis of the mirror is to coincide with the mechanical axis of the tube, and if the last part of the converging beam is to be diverted through 90° so that its axis coincides with that of the eyepiece, a high degree of angular precision is called for. The attainment of such precision by purely mechanical means is hardly possible for the amateur;

but fortunately other means are available. It is only necessary to construct the whole telescope tube and optical cells to a fair degree of accuracy, incorporating means by which adjustments can be carried out and checked by very simple optical tests.

Some sort of focussing attachment will have been provided by which the eyepiece can be moved a short distance along the diverted part of the optical axis. It is desirable that this part of the axis should be, as nearly as possible, at right angles to the tube. If we start with the focussing attachment itself, we can ensure that this condition exists, and steer clear of complications which might otherwise arise when adjusting the mirror and flat.

The base of the focussing attachment (and it matters not at all how simple this is) should be screwed to the tube wall with small spring-washers between the tube and itself; diametrically opposite the centre of the eyepiece tube a small hole should be drilled in the telescope tube, to act as a target and to provide a permanent reference mark. In the end of the eye tube furthest from the eye a round plug of card with a central hole should be inserted; this forms a "peepsight" and should be used for adjusting the base by its screws until it points directly at the drilled hole. So far so good; the axis of the eyepiece will now be perpendicular to that of the main tube.

Mounting the "Flat"

The elliptical plane mirror can well be mounted at the end of a short, rigid, post. There are other more elaborate methods but, whatever the means, it must be rigidly held. If the post is made with a base extended along the telescope tube as indicated, and the

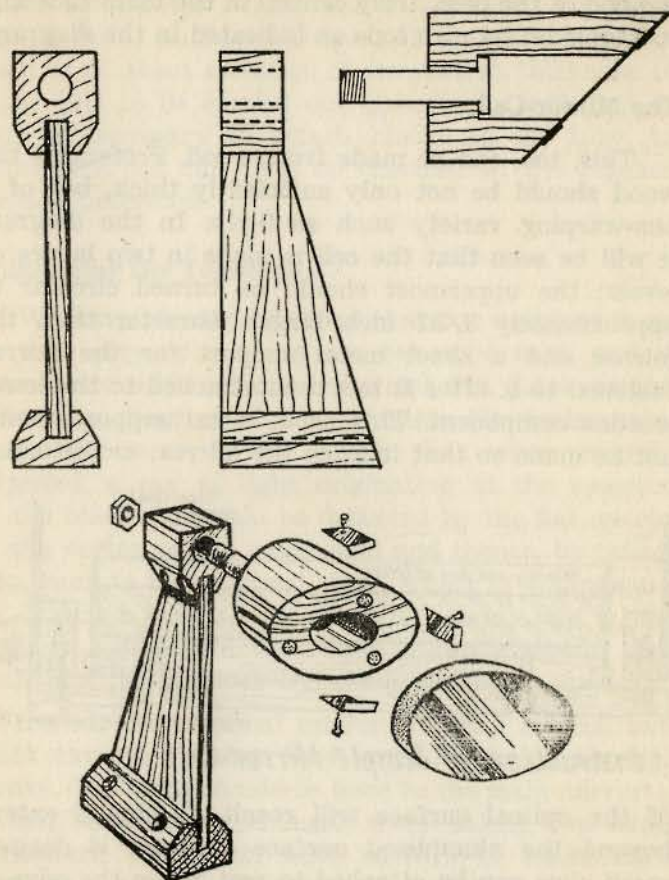

Mounting the Newtonian Flat

bolts or screws are made to pass through "over-size" holes, the use of ordinary washers, plus tough spring washers, will make available a complete range of adjustment. To be sure, such an arrangement is not the most elegant that could be devised, but this is immaterial. The small mirror itself should be held at

the end of the post, truly central in the main tube and rotatable on its own axis as indicated in the diagram.

The Mirror-Cell

This, too, can be made from wood. Preferably the wood should be not only sufficiently thick, but of a non-warping variety such as 9-ply. In the diagram it will be seen that the cell is made in two layers or levels; the uppermost should be turned circular to approximately $1/32$ inch larger diameter than the mirror and a sheet metal support for the mirror fastened to it after it has been attached to the lower wooden component. This sheet metal support should not be made so that it grips the mirror, or distortion

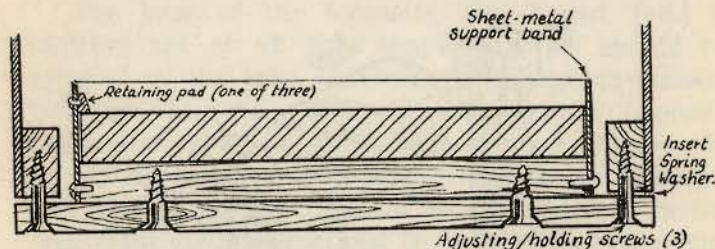

Construction of Simple Mirror-Cell

of the optical surface will result. It should extend beyond the aluminised surface so that, if desired, small clips can be attached to rest above the edge of the mirror. The value of these is largely psychological, since there is no likelihood of the mirror being tipped out of its cell in ordinary use on astronomical subjects. The diagram should make the general arrangement perfectly clear; for simplicity, the complete cell can be attached to the telescope tube in exactly the same fashion as the focussing mount was attached.

Three screws (or studs) will be sufficient, but these should be of sufficient weight. If the telescope tube itself is of sheet metal or of insufficient thickness to allow this to be carried out directly, as indicated, it will be necessary to attach blocks to the tube, to which the cell can then be fastened in the manner already described.

Collimating the Telescope

We have already assumed that our eyepiece is on an axis perpendicular to the telescope tube, and it remains to adjust the mirror and flat. Look at the schematic diagram of the complete Newtonian telescope once more. It will be seen that, when properly adjusted, a ray of light originating at the eyepiece of the telescope would be deflected by the flat mirror to the vertex of the paraboloid and thence, by reflection, back to the elliptical plane, where it would again be deflected back to its point of origin; this is the state of affairs we have now to bring about, and these are the methods by which we shall achieve it.

Across the elliptical mirror we shall stretch two black threads so that they cross at its geometrical centre. The same should be done to the main mirror—in fact no harm would result from making two small permanent marks on both mirrors to mark their centres. With the peepsight still in the eyepiece tube, adjust the elliptical mirror by means of the screws and spring washers, until the point at which the threads cross can be seen to be in the centre of the peepsight. Ignore the reflections that can be seen in the flat. Simply ensure that the centre of the flat is on the axis of the eyepiece; now remove the peepsight and continue to adjust the flat until its crossed threads

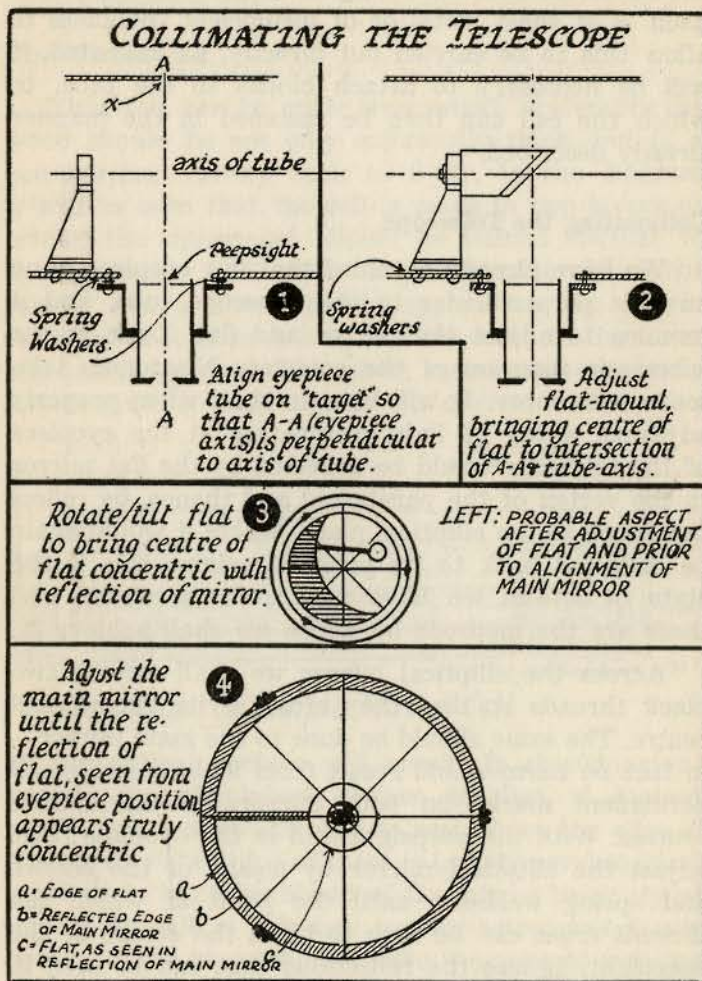

intersect at the same point as the reflection of the black threads over the main mirror. As soon as we have this condition, we know that the surface of the "flat" has its centre on (a) the axis of the eyepiece and (b) on that of the mechanical axis of the telescope tube—it also lies in a plane 45° to both. During all this time the main mirror's view (which can be seen by reflection in the flat) should be completely ignored; it remains to bring the optical axis of the main mirror into coincidence with that of the telescope tube and the job is complete.

With a telescope as long as the average six-inch reflector is likely to be, it will simplify matters when collimating for the first time if some assistance is available. Adjustments to the main mirror cell can then be carried out under conditions of continuous observation through the eyepiece tube, and there is no reason at all why these should take more than two or three minutes.

Our problem now is simply to adjust the mirror by means of the three springloaded screws, until it looks squarely down the length of the tube. It is likely that the reflection of the mirror as seen in the flat will, before this last adjustment, show a good deal of the wall of the tube, with perhaps a more or less "gibbous moon" view of the daylight sky—or whatever the telescope happens to be pointed at. Somewhere, superimposed on this view, will be a reflection of the flat and its supporting post. A closer examination of this part of the reflection will show that the aperture of the eye tube can itself be seen. Slight tilting of the mirror by means of the screws will quickly bring this reflection of the flat so that it appears centred on the intersection of the crossed

threads already described; it may help to re-insert the small card "peepsight" in the eye-tube for final adjustment. Now remove the peepsight if it has been used, and the following should be seen. First, the flat itself—appearing circular owing to its inclination of 45° . In this will be seen the circular outline of the mirror with its centre falling on the centre of the flat. In the centre of the reflected view of the mirror is a twice-reflected view of the flat (still circular) with a "hole" in its centre, which is the eye tube. If the observer withdraws his head slightly so that a reasonable amount of daylight can fall on his eye, he should see, at the very centre of this scheme of concentric circles, the reflection of his own eye. The conditions we set out to obtain are now met with: a ray of light originating at the eyepiece is travelling, *via* the flat, to the vertex of the mirror and back again without sensible deviation; the telescope is "collimated" and will now yield the best possible definition of which it is capable under any given conditions.

Mounting a Telescope

If the observer intends to mount the telescope himself, and has never before attempted such a task, it is probably better to "knock up" a rough and ready stand, than to attempt to produce an ideal mounting at the first attempt. The rough and primitive mounting will serve two purposes; first it will afford a means of actually trying out the telescope on the kind of subject for which its optics are designed, and, second, the practical lessons learned from its inevitable deficiencies will prove of great value, and, if properly absorbed, will result in a far better ultimate mounting than might otherwise be the case.

Let it be said here and now that the variety of ready-made discarded machine parts that have been pressed into service by amateur observers (often with great success) is quite remarkable. Intelligent choice and use of such items is most likely to be made by those who have already constructed a mounting from scratch, no matter how simple it might be.

Within the limits imposed by the materials used, and by the facilities available, the principal considerations must be (a) freedom from shake and (b) smooth rotation of the telescope on its axes. Both these considerations are of equal importance.

We have a certain amount of choice, whatever the materials used, in the actual form of the telescope mounting. The principal axis can be vertical; or it can be made so as to lie parallel with the axis of the earth itself. In the former case, the constant following of a star will necessitate more or less continuous movement of the telescope on *both* axes, and, in the latter case, movement of the principal axis alone will suffice, once the telescope has been directed to the intended subject of observation, to counter the movement of the Earth, and keep the subject in view. Nevertheless, especially when using ready-to-hand materials, the former type of mounting (altazimuth) presents fewer mechanical problems and this is the type of mounting we shall deal with in the greatest detail, as being the most suitable for a first mounting and the most likely to be successful.

In the diagram shown on page 118 the two axes (vertical and horizontal) are, respectively, the azimuth and altitude movements, on which the locating and

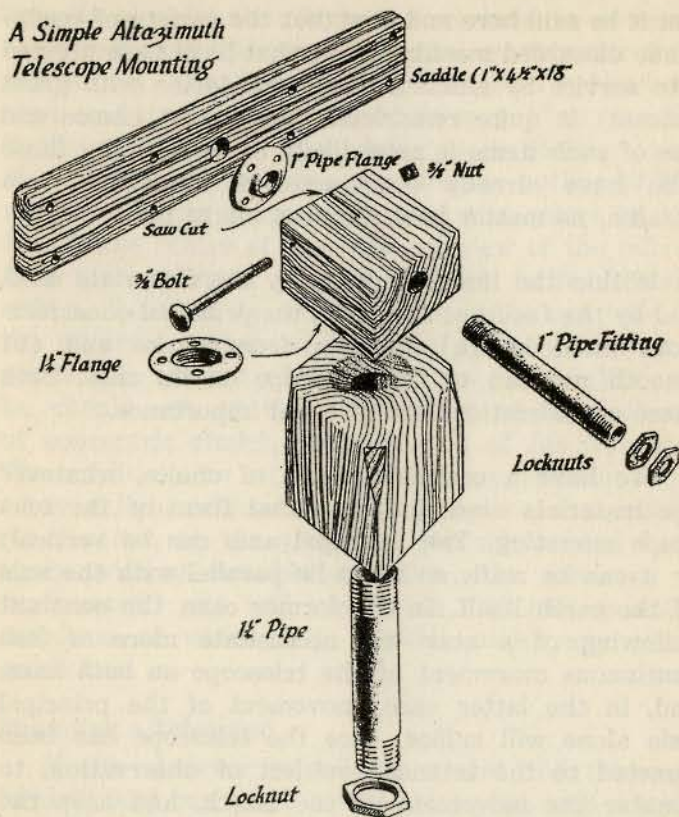
A Simple Altazimuth
Telescope Mounting

following of sky objects have to depend; in its most simple form, and for temporary use, such a mounting can be made entirely from wood and standard pipe-fittings. These are the means which have been assumed to be most readily accessible, and hence chosen as the basic materials for this simple design. Those who feel the need for more elaborate materials, and who have the means for putting their ideas into effect, should find little difficulty in translating the

suggestions made here concerning the wood and pipe-fitting mounting into a form suited to the materials of their own choice.

The moving parts are simple in the extreme; the two large blocks through which pass the axles should, for preference, be of a good quality hardwood. The smaller, upper block, forms the bearing for the pipe-fitting, which comprises the altitude movement. For mechanical reasons this upper block should be as shallow as is consistent with the mechanical strength necessary to provide a suitable housing and bearing for the axle when carrying the weight of the telescope. A saw-cut opening the wood block, and extending for six inches along its length will, by means of a long bolt as shown, permit some adjustment of the firmness of the bearing by increasing the turning-friction when tightened. For preference, both pipe-fittings forming the axles should be machined in a lathe, if one is available, as the increased smoothness of movement will be well worth while. The lower block is "relieved" in the centre to permit the flange at the upper end of the azimuth axis to lie clear of the wood. It can be seen that the base of the upper axle is bearing on the wood of the lower block; for this reason these adjacent surfaces should be planed and sanded as true and smooth as possible. A far better solution, even when the greater part of the mounting is wood, is to make use of a suitable Timken or similar thrust-type bearing at the lower and upper ends of the axle. These can frequently be obtained from a car breaker at low cost.

While the sketch on page 118 is largely self-explanatory, attention must be drawn to the following features of the wooden mounting. The saw-cut shown

in the block, which provides the bearing for the altitude axis, should be of sufficient width, and extend for a distance great enough to provide a reasonable amount of "spring," in order that the turning-friction on this axis can be adjusted within reasonable limits by the bolt passing through it.

It should be noticed, too, that the upper end of the azimuth axis housing is relieved to make room for the flange in which is fastened the azimuth axle; this means that the wood itself provides the thrust-bearing. This being so, it is essential, if ball-races are not to be included in the design, to see that the adjacent bearing surfaces are planed and smoothed as true as possible. Some improvement in performance could be expected from the inclusion of an annular plate of brass or, in fact, almost any other metal of sufficient hardness and thickness between the two wood surfaces. If possible, the flange to which the axle is screwed should itself be faced perpendicular to the axis, in a lathe, before attaching it to the altitude axle-housing, to ensure that the two axes are truly at right angles, and that the underside of the altitude housing is drawn down parallel to the upper end of the azimuth axis housing.

Since the telescope is not counterpoised, it will pay to consider the whole system as an arrangement of levers by which thrust is exerted at a number of points; since any shock or accidental pressure will be transmitted through these "levers" and result in undesirable movement of the telescope they should be kept as short as possible in order to reduce their effect to a minimum.

In particular, the forces exerted on the declination axis should be as equally distributed as possible

and fall where they can be most easily supported by the structure. To this end, in the example sketched here, it will be seen that the extremes of the altitude axis are kept as nearly as possible directly over the azimuth bearing; in addition, the telescope tube itself is made to "hug" the bearings of the axle which carries it. *This can hardly be overdone*; the more compact the upper end of the mounting can be, consistent with a sufficiently extended bearing surface, the more rigid and free from tremble will be the telescope. Notice, too, that the flange is not fastened directly to the tube of the telescope but to a rigid beam which extends for some distance along the tube; the more rigid this beam is, the better will be the results. Ideally it would be made of iron or steel, with the telescope itself carried in rings attached to its extremities. It should be understood, too, that if some modification of this type of mounting, to adapt it to an equatorial form, is attempted, its importance will be even greater since the telescope will frequently be in positions that would lead to impossible amounts of flexure of a flimsy beam.

The diagram on page 122, which should require no detailed explanation, shows a particularly good form of mounting for an equatorially mounted reflector. It is simple to make and, if proper bearings are provided at each end of the frame which, in effect, forms the polar-axis, it will be found to be a very fine type of permanent mounting. It is included here because it is probably the only form of equatorial mounting which can, if necessary, be carried out successfully without the use of a lathe. If two closely telescoping rods are carried from swivels at the upper end of the telescope tube to the bottom of the frame, they

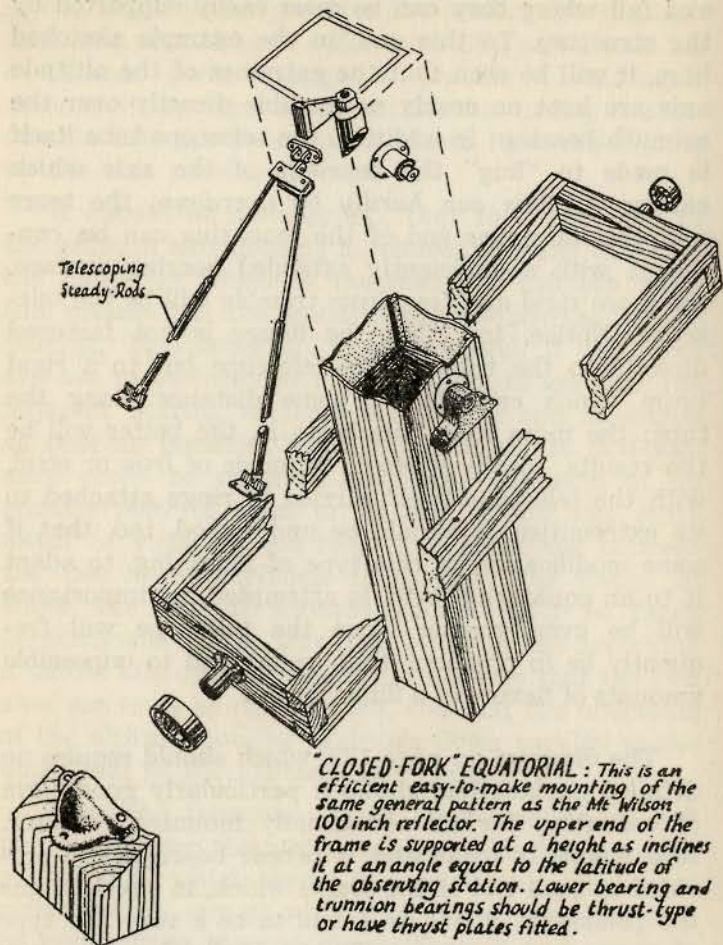

"CLOSED-FORK" EQUATORIAL: This is an efficient easy-to-make mounting of the same general pattern as the Mt. Wilson 100 inch reflector. The upper end of the frame is supported at a height as inclines it at an angle equal to the latitude of the observing station. Lower bearing and trunnion bearings should be thrust-type or have thrust plates fitted.

will act not only as "steadies" but, if marked at suitable intervals, will provide a rough and ready means of setting the telescope approximately in any desired declination. There are many quite successful examples of this mounting in operation today, perhaps the most famous of them being that of the 100 inch

telescope at Mt. Wilson in California. Almost the entire job, apart from the axles, bearings, and steady-rods can be carried out in wood.

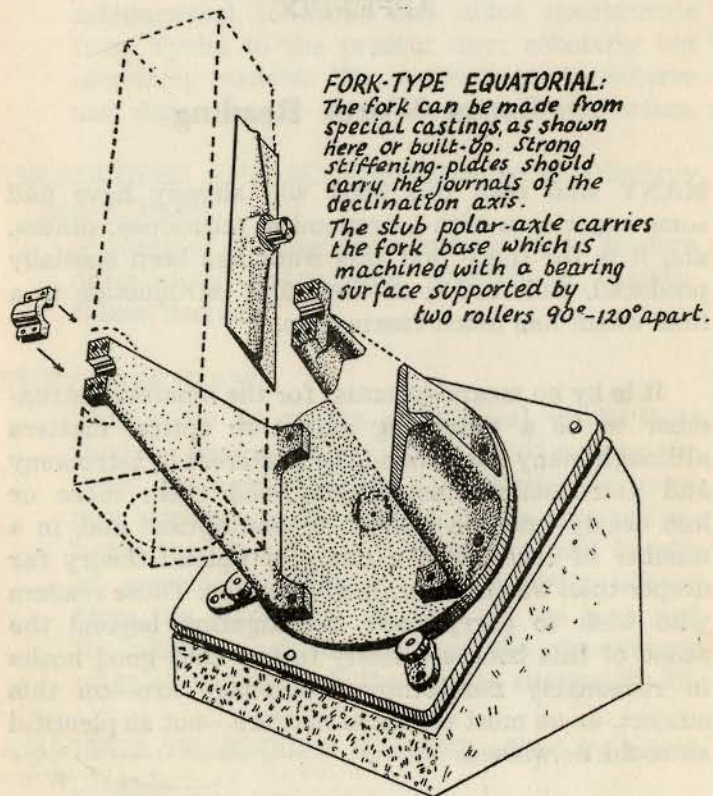

FORK-TYPE EQUATORIAL:

The fork can be made from special castings, as shown here or built-up. Strong stiffening-plates should carry the journals of the declination axis.

The stub polar-axle carries the fork base which is machined with a bearing surface supported by two rollers 90°-120° apart.

APPENDIX

Books Worth Reading

MANY who read this book will already have had some experience with astronomical telescopes; others, and it is for these that this work has been specially produced, will read it as their first introduction to a field which has much fascination.

It is by no means essential for the amateur astronomer to be a practising expert in optical matters although many have found their interest in astronomy and astronomical instruments lead them more or less deeply into the field of applied optics; and, in a number of cases, into a study of optical theory far deeper than was their original intention. Those readers who wish to carry their investigation beyond the scope of this book are likely to find that good books in reasonably non-technical language are—on this subject, as on most technical matters—not as plentiful as could be wished.

Nevertheless, there are a number of books which can be recommended, and, although several of them are of American origin, most of them can be obtained on loan through Public Libraries. A brief list follows, together with an indication of the subject matter covered.

APPENDIX

Books Dealing With Astronomical Instruments

HISTORY OF THE TELESCOPE by H. C. King.

A fascinating account of the development of the astronomical telescope and allied instruments from Tycho to the present day; scholarly but extremely readable. The writer is public lecturer and demonstrator at the London Planetarium.

TELESCOPES AND ACCESSORIES by G. Dimitrov and H. Baker.

A study of the use and construction of modern observatory instruments, written in easy-to-follow language.

THE GLASS GIANT

This is by no means a technical work. It is the true account of the adventure of making the great 200-inch telescope (the world's largest) now working on Palomar Mountain. The vicissitudes that befell the project, the cold breath of near-disaster which seemed never absent from the workshops engaged on the task and the ultimate establishment of the observatory make an exciting tale that can be enjoyed by all.

AMATEUR TELESCOPE MAKING, edited by Albert W. Ingals.

Popularly known as "ATM" this book has run through many editions (with constant improvement and additions since it was first published a quarter of a century ago). It provides an immense amount of information for the home telescope-builder.

AMATEUR TELESCOPE MAKING—ADVANCED

Covers somewhat similar ground to the preceding work, but deals with amateur-made instruments of somewhat greater refinement.

AMATEUR TELESCOPE MAKING Bk. III.

The articles in this work go into deeper theoretical territory than either of the two previous works of the series; considerable information is provided concerning objective and camera lens computation, diffraction theory, binocular collimation, Schmidt telescope construction, and the quartz-polaroid monochromator. Not a work for the beginner.

MAKING YOUR OWN TELESCOPE by Allyn J. Thompson.

This book is published by the Sky Publishing Corp., Harvard College Observatory, and deals with the construction, step by step, of an amateurs' six-inch reflector as built in considerable numbers by a group of amateur constructors in New York.

Among works not commonly available but which can be found in some reference libraries are the following works of practical and historical interest:

THE COLLECTED SCIENTIFIC PAPERS OF SIR WILLIAM HERSCHEL.

Published by a joint-commission of the R.S. and R.A.S., this work contains the great astronomer's own account of the design, making and mounting of the great 48-inch aperture reflecting telescope—for many years the largest telescope in existence.

THE MAKING OF SILVERED-GLASS REFLECTING TELESCOPE, by Draper and Ritchie. (Smithsonian Institute.)**Books On Astronomy****STARS IN THE MAKING**, by Cecilia Payne-Gaposchkin.

An exceedingly well written and richly illustrated work setting before the reader, in understandable language, some of the more advanced ideas current concerning the evolution of stars and galaxies.

INTRODUCTION TO ASTRONOMY, by the same Author.

A first class book on general astronomy and scientists' methods, as applied to the study of the most distant reaches of space.

THE SUN, by G. Abetti.

A very complete study of the modern state of knowledge concerning our nearest star.

GUIDE TO THE MOON, by Patrick A. Moore.

A lively and readable book by one of the most prominent lunar observers in Britain. The lunar surface is described in considerable detail and some of the theories concerned with the origin of the lunar surface-features are discussed.

OTHER WORLDS IN SPACE, by Terry Maloney.

This is a readable and up-to-date account of the planetary bodies of the Solar system. Profusely illustrated by the author, the book deals in some detail with the various planets in turn. A fairly complete glossary of astronomical terms at the end of the book will be of great

value to those intending to pass on to more specialised, less "popular," works on astronomy.

ASTRONOMY, by Russell, Dugan and Stewart.

In two volumes. This work has for long been regarded as the standard textbook on astronomy in the United States. The latest edition, especially the second volume (Sidereal Astronomy), has been considerably revised in the light of recent knowledge.

THE LAST 100 YEARS IN ASTRONOMY, by R. A. Waterfield.

This book has been out of print for some time but can still be found in Public Libraries; the great strides made during the century under review and the accelerating progress resulting from the development of spectographic and photographic methods are illustrated by accounts which, while written in a pleasingly simple style, manage to convey something of the author's own enthusiasm for his subject.

NORTON'S STAR ATLAS.

(Published by Gall & Inglis.)

The standard "observers' guide" not only in Britain but in many other countries. A series of well-planned and clearly-printed charts covers the whole sky of both hemispheres and includes many "telescopic objects" such as nebulae, globular clusters, etc.

THE STARRY HEAVENS by Ellison Hawk.

Profusely illustrated. This interesting work deals with the Planetary system outwards.

AMATEUR ASTRONOMER'S HANDBOOK by Sidgwick.

A reference handbook of great importance covering all types of instruments and apparatus of interest to the amateur astronomer.

SPACEFLIGHT.

A popular yet authoritative magazine published by The British Interplanetary Society.

SKY AND TELESCOPE.

An extremely readable and informative monthly magazine published by Sky Publishing Corp., Mass., U.S.A.

In addition to the works listed the beginner would do well to consult the various books in the excellent series "HARVARD BOOKS ON ASTRONOMY." These are written by astronomers of world repute, and the subjects range from Meteors to Galaxies.

Aids for Star Study

George Philip of London publishes several excellent aids for Star Study. The following are particularly useful:

PHILIP'S PLANISPHERE.

Showing the principal stars visible for every hour in the year.

PHILIP'S CHART OF THE STARS, edited by E. O. Tancock.

A chart of the middle heavens surmounting two circular diagrams of the Polar constellations.

PHILIP'S MAP OF THE MOON.

Showing its principal physical features.

BALL'S GUIDE TO THE HEAVENS.

An excellent guide—profusely illustrated.

ELGER'S MAP OF THE MOON

A canvas mounted chart 30 inches by 19½ inches identifying all the important lunar features.

Astronomical Societies and Associations

Throughout the world there are innumerable societies in which membership is open to persons interested in astronomy. The enthusiast would do well to join his local Astronomical Association and if he is considering the construction of a reflecting telescope, he is bound to find amongst the members enthusiasts who will be happy to offer help and guidance.

The British Astronomical Association has its headquarters in London and branches have been formed throughout Britain and the Commonwealth. In London members meet at the Royal Astronomical Society Rooms, Burlington House, Piccadilly, usually on the last Wednesday of each month. Details of membership can be obtained from the Assistant Secretary at the Registered Office of the Association, 303 Bath Street, Houston West, Middlesex.

The Junior Section of the Society is intended for people of all ages who are interested in astronomy, but who are not experienced observers.

INDEX

- Aberration, 3, 7, 9, 45, 63, 99-100
 chromatic, 7, 63
 spherical, 3, 9, 45, 99-100
 Achromatic, 25, 35, 75, 92
 Aero-Ektar, 59
 Altazimuth, 117ff.
 Altitude, 85, 117
 Altitude scale, 30, 85
 Aluminising, 47, 49
 Andromeda, 24, 54
 Anti-aircraft identification telescope, 29
 Aperture, 9, 21, 23, 64, 65
 Ascension, 83
 Astigmatism, 71, 74
 Atmosphere, 37
 Attachments, 79
 Axis, optical, 2, 30
 polar, 96
 Azimuth, 117
 scale, 30
 Back-focus, 71
 Barlow lens, 54-55, 80, 94
 Binoculars, 23, 26, 32ff.
 Broken transit, 86
 Cambridge, 88
 Camera, 30
 guiding, 60
 Cassegrain telescope, 93, 94ff.
 Catadioptric, 102
 Choice of telescope, 20
 Chromatic aberration, 7
 Chronograph, 83
 Clock drive, 30
 Collimation, 84, 105, 113ff.
 Colour, 6
 correction, 77
 Coma, 109, 101
 Comets, 56
 Cooke, 59
 Corona, 105-106
 Coronagraph, 105-106
 Correcting plate, 101
 Coudé, 86, 95
 Counterpoise, 120
 Cygnus, 23
 Dark nebulae, 23
 Declination, 83
 axis, 120
 Definition, 31
 Diagonals, 14, 47, 79
 solar, 14, 79
 stellar, 79
 Diffraction grating, 107
 pattern, 20, 65
 Diminishing glass, 5
 Dispersion, 7
 Double star, 11
 Double-double, 65
 Earth's rotation, 69
 Eclipse, 88, 105
 Elbow telescope, 25, 28, 29, 77
 Epsilon Lyrae, 65
 Equatorial, 31, 35, 86
 Equatorial mounting, 121-123
 fork-type, 123
 Erect image, 26, 32
 Erecting system, 25, 29
 Ernie, 77
 Eye-beam, 28
 Eyepiece, 68ff., 109
 Ernie, 77
 fixed, 87
 Huyghenian, 63, 73
 Kellner, 74
 low-power, 10, 12
 Monocentric, 75
 negative, 73
 orthoscopic, 75, 76, 77
 Ramsden, 74, 75
 Steinheil Monocentric, 75
 Tolles, 76
 Zeiss, 76
 Eye-point, 71
 Eye-pupil, 71, 74
 Eye-relief, 71, 74
 Figure, 43, 99
 Finder, 22, 29
 Fixed eyepiece, 87
 Flat, 49-50, 97, 110
 mounting, 110ff.
 size, 51
 Flint, 77
 Focal length, 2, 8, 74, 80
 Focal plane, 2, 80
 Focussing, 110
 Fog, 66
 Fork-type equatorial, 123
 Fraunhofer, 86
 Galilean telescope, 5
 Galileo, 5
 Ghosts, 25, 75, 76
 Goerz, 55
 Gregorian telescope, 93ff.
 Guide star, 61
 Guiding, 56, 60
 Hand telescopes, 33
 Haze, 66
 Heliostat, 89, 90, 107
 High power, 69
 Huyghenian eyepiece, 63, 73
 Infra-red filter, 14
 Inverting prism, 5
 Iris, 29
 Jupiter, 12, 25, 31
 satellites, 26
 Kellner, 74
 Kepler, 73
 Length, focal, 2
 Lenses, 2ff., 58ff.
 Aero-Ektar, 59
 dispersion, 7
 meniscus, 102-103
 moulded, 9
 negative, 5
 positive, 4
 Rapid Rectilinear, 58
 symmetrical, 58
 Light-grasp, 9, 19, 21, 28, 64
 Lippershey, 5

- Lyot Coronograph, 105-106
- Magnification, 12, 19, 27, 28, 31
- Magnifying power, 70
- Maksutov-Cassegrain, 103
- Maksutov-Gregorian, 104
- Maksutov telescope, 102ff.
- Martian canals, 20
- Medium power, 29
- Meniscus lens, 102-103
- Meridian circle, 85
- Messier, 24
- Meteors, 26, 56, 59
- Milky Way, 11, 23, 58
- Mirror, 21, 46ff., 109ff.
figure, 46
- Mirror-cell, 112-113
adjusting, 115-116
- Mirror-reversal, 98
- Monocentric, 75
- Moon, 12ff., 41-42, 62
craters, 41
- Moulded lens, 9
- Mounting, 30, 34, 36, 40, 45, 53,
82ff., 116ff.
altazimuth, 117ff.
counterpoise, 120
equatorial, 121-122
fork-type equatorial, 123
Porter-Springfield, 87, 96ff.
Springfield, 96ff.
stability, 53, 64
tripod, 34
vibration, 36
- Newtonian reflector, 41ff., 94, 96,
109
- Night-field glass, 5
- Non-achromatic, 32
- Non-achromatic telescope, 8
- Object-glass, 18, 21, 28, 31
- Occulting disc, 105
- One-inch telescope, 12
- Opera glasses, 5
- Optical axis, 2, 100, 109
- Optical polish, 8
- Orion, 24
- Orthoscopic, 75, 76, 77
- Paraboloid, 47, 93, 100, 109
- Paris Observatory, 83
- Petzval, 58
- Photography, 50-51, 53ff.
guiding, 56, 60
meteors, 59
Milky Way, 58
Moon, 57
spectra, 56
Sun, 57
ultra-violet, 53
wide-field, 56
- Photosphere, 105
- Pickering-Harvard, 88, 91, 92
- Point image, 19
- Polar axis, 96
- Polaroid, 107
- Portability, 21, 32, 34, 35
- Porter-Springfield, 87, 96ff.
- Predictor, 25, 29
- Prism, 5, 6, 49, 79, 97
- Prismatic effect, 74
- Pulkhovo, 104
- Quartz, 107
- Ramsden, 71, 74, 75
- Ramsden disc, 71
- Rapid Rectilinear, 58
- Reciprocity failure, 59
- Reflector, 21, 41ff., 48, 68
- Refraction, 66
- Refractor, 34ff., 73
cost, 35
- Resolving power, 8, 10, 19, 21, 64
- Richest field, 23
- Right Ascension, 83
- Ross, 59
- Rotation, 30, 54, 86
- Scanning, 107
- Schmidt telescope, 100ff.
- Scratches, 8, 9
- Setting circles, 23
- Sheepshanks, 88
- Sidereal time, 83
- Size of telescope, 18ff.
- Small telescope, 22
- Solar (see 'Sun')
- Spectra, 56, 79, 92, 107
- Spectrograph, 88, 90
- Spectroheliograph, 106
- Spectroscope, 107
- Spherical aberration, 3, 9, 45,
99-100
- Spikes, 49
- Springfield, 96ff.
- Stability, 53, 64, 85
- Star brightness, 43
clusters, 27
magnitude, 43-44
- Steinheil Monocentric, 75
- Stop, 10
- Stopping down, 9, 71
- Sun, 13ff., 26, 64, 88, 105
caps, 14
corona, 26, 105-106
dangers, 13, 64
diagonal, 14, 79
observation, 14ff.
prominences, 106-107
sunspots, 14, 27, 106
telescopes, 88
- Sunspots, 14, 27, 106
- Symmetrical lenses, 58
- Telephoto lens, 55
- Tolles, 76
- Tower telescope, 89
- Transit, 82ff.
- Triplet, 76
- Variable stars, 50
- Vignetting, 50
- Voigtländer, 55
- War-surplus, 25ff.
- Wave-front, 18
- White light, 6
- Wide field, 22, 27, 56
- Working distance, 74
- Wray, 59
- Zeiss, 75, 76
- Zenith, 80



Published by

CHARLES FRANK
of the **SALTMARKET, GLASGOW**

Makers and Suppliers of Telescope Mirrors, Optical,
Scientific and Photographic Apparatus.

FRANK'S BOOK OF THE TELESCOPE